

2990AW FeatureLine

INSTALLATION INSTRUCTIONS

290 Humberline Drive · Toronto, ON M9W-5S2 · 416-745-4222

GENERAL CONSTRUCTION NOTES3

PARTS LIST4-7

DETAILS8-9

FRAME FABRICATION

 Frame fabrication10-14

 Mitered Frame fabrication15-17

FRAME ASSEMBLY

 Typical Frame Assembly18-20

 Frame Sealing.....21-22

 Attach Strap anchors and mullion reinforcement.....23

FRAME INSTALLATION

 Frame Installation into rough opening.....24



 1375AW Window installation into Framing.....25

 5000 Phantom Vent installation into Framing.....26

GLAZING

 Glazing27-28

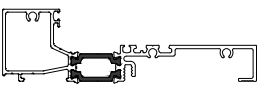
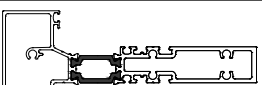
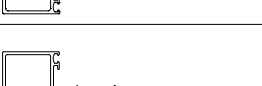
1. These instructions cover typical product application, fabrication, installation and standard conditions and are general in nature. They provide useful guidelines, but the final shop drawings may include additional details specific to the project. Any conflict or discrepancies must be clarified prior to execution.
2. Materials stored at the job site must be kept in a safe place protected from possible damage by other trades. Stack with adequate separation so materials will not rub together and store off the ground. Cardboard or paper wrapped materials must be kept dry. Check arriving materials for quantity and keep a record of where various materials are stored.
3. All field welding must be done in accordance with AISC guidelines. All aluminum and glass should be shielded from field welding to avoid damage from weld splatter. Results will be unsightly and may be structurally unsound. Advise general contractor and other trades accordingly.
4. Coordinate protection of installed work with general contractor and/or other trades.
5. Coordinate sequence of other trades which affect framing installation with the general contractor (e.g. fire proofing, back up walls, partitions, ceilings, mechanical ducts, HVAC, etc.).
6. General contractor should furnish and guarantee bench marks, offset lines and opening dimensions. These items should be checked for accuracy before proceeding with erection. Make certain that all adjacent substrate construction is in accordance with the contract documents and/or approved shop drawings. If not, notify the general contractor in writing before proceeding with installation because this could constitute acceptance of adjacent substrate construction by others.
7. Isolate all aluminum to be placed directly in contact with masonry or other incompatible materials with a heavy coat of zinc chromate or bituminous paint. Fasteners attaching framing to building structure are typically not provided by Alumicor.
8. Sealant selection is the responsibility of the erector, installer and/or glazing contractor and must be approved by the sealant manufacturer with regard to application and compatibility for its intended use. All sealants must be used in strict accordance with the manufacturer's instructions and applied only by trained personnel to surfaces that have been properly prepared.
9. Sealant must be compatible with all materials with which they have contact, including other sealant surfaces. Consult the sealant manufacturer for recommendations relative to shelf life, compatibility, cleaning of substrate, priming, tooling, adhesion, etc. Recommend sealant manufacturer perform adhesion "pull test" at "wet" glazing for quality assurance.
10. Drainage gutters and weep holes must be kept clean at all times. Alumicor will not accept responsibility for improper drainage as a result of clogged gutters and weep holes.
11. This product requires clearances at the head, sill and jambs to allow for thermal expansion and contraction as well as construction tolerances. Refer to final distribution drawings for joint sizes. Joints smaller than 1/2 " may be subject to failure. Consult the sealant manufacturer for proper sizing of joints.
12. All framing members, entrances and other materials are to be installed plumb, level and true with regard to established bench marks, column center lines or other working points established by the general contractor and checked by the erector, installer and/or glazing contractor.
13. After sealant is set and a representative amount of the wall has been glazed (500 square feet or more), run a water hose test to check installation. On large projects, a hose test should be repeated during glazing operation. This testing should be conducted in accordance with AAMA 501.2 specifications.
14. Cleaning of exposed aluminum surfaces should be done per AAMA recommendations.
15. Care must be taken when assembling aluminum framing components. Over tightening any fastener may cause stripping or fastener failure. Alumicor recommends the use of drill motors with clutches engaged to provide satisfactory tightening of the screw while preventing over torque. The use of impact drill motors is not recommended due to the absence of a clutch device.
16. Primary dimension are in inches and dimensions in [] are in millimeters. All dimensional tolerances are: .XXX±.010" [.254] , .XX±.03" [0.76], .X±.1" [2.54], angular ± .1°
17. Check www.alumicor.com for any installation instruction updates.

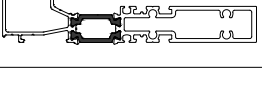
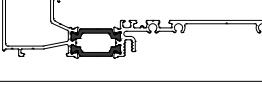
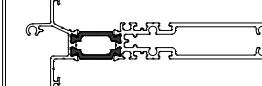
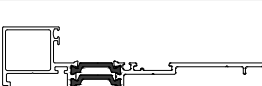
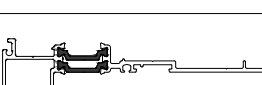
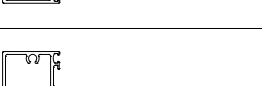
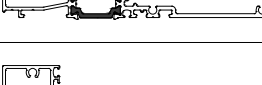
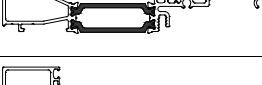
SHAPE	Part No.	DESCRIPTION	Notes
	A299201XX	5 1/4" [134mm] 2990 DOUBLE GLAZED PERIMETER FRAME	24 FT STOCK LENGTH
	A299202XX	5 1/4" [134mm] 2990 DOUBLE GLAZED INTERMEDIATE MULLION	24 FT STOCK LENGTH
	A299203XX	5 1/4" [134mm] 2990 DOUBLE GLAZED SPLIT MULLION-MALE	24 FT STOCK LENGTH
	A299204XX	5 1/4" [134mm] 2990 DOUBLE GLAZED SPLIT MULLION-FEMALE	24 FT STOCK LENGTH
	A299205XX	5 1/4" [134mm] 2990 DOUBLE GLAZED PERIMETER FRAME CLOSED BACK	24 FT STOCK LENGTH 45° FRAME CUT
	A299221XX	6" [153mm] 2990 DOUBLE GLAZED PERIMETER FRAME	24 FT STOCK LENGTH
	A299222XX	6" [153mm] 2990 DOUBLE GLAZED INTERMEDIATE MULLION	24 FT STOCK LENGTH
	A299223XX	6" [153mm] 2990 DOUBLE GLAZED SPLIT MULLION-MALE	24 FT STOCK LENGTH
	A299224XX	6" [153mm] 2990 DOUBLE GLAZED SPLIT MULLION-FEMALE	24 FT STOCK LENGTH
	A299225XX	6" [153mm] 2990 DOUBLE GLAZED PERIMETER FRAME CLOSED BACK	24 FT STOCK LENGTH 45° FRAME CUT
	A299301XX	6" [153mm] 2990 TRIPLE GLAZED PERIMETER FRAME	24 FT STOCK LENGTH
	A299302XX	6" [153mm] 2990 TRIPLE GLAZED INTERMEDIATE MULLION	24 FT STOCK LENGTH
	A299303XX	6" [153mm] 2990 TRIPLE GLAZED SPLIT MULLION-MALE	24 FT STOCK LENGTH

AVAILABLE FINISHES









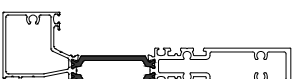
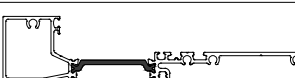
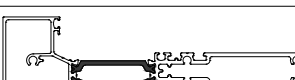
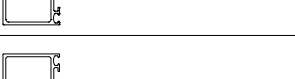
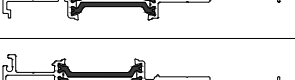
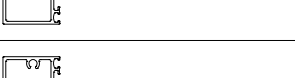

(00) Mill Finish
(73) Black

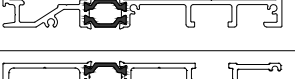
(28) Medium Bronze
(75) Light Bronze

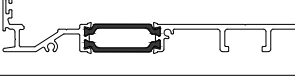
(41) Clear Class 2
(76) Champagne



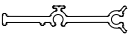



(42) Dark Bronze
(09) Painted

(71) Clear Class 1

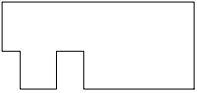
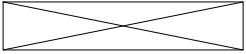
	A299304XX	6" [153mm] 2990 TRIPLE GLAZED SPLIT MULLION-FEMALE	24 FT STOCK LENGTH
	A299305XX	6" [153mm] 2990 TRIPLE GLAZED PERIMETER FRAME CLOSED BACK	24 FT STOCK LENGTH 45° FRAME CUT
	A299321XX	6 3/4" [171mm] 2990 TRIPLE GLAZED PERIMETER FRAME	24 FT STOCK LENGTH
	A299322XX	6 3/4" [171mm] 2990 TRIPLE GLAZED INTERMEDIATE MULLION	24 FT STOCK LENGTH
	A299323XX	6 3/4" [171mm] 2990 TRIPLE GLAZED SPLIT MULLION-MALE	24 FT STOCK LENGTH
	A299324XX	6 3/4" [171mm] 2990 TRIPLE GLAZED SPLIT MULLION-FEMALE	24 FT STOCK LENGTH
	A299325XX	6 3/4" [171mm] 2990 TRIPLE GLAZED PERIMETER FRAME CLOSED BACK	24 FT STOCK LENGTH 45° FRAME CUT
	A294201XX	5 1/4" [134mm] DUAL GLAZED SILL RECEPTOR	24 FT STOCK LENGTH
	A294202XX	5 1/4" [134mm] DUAL GLAZED JAMB & HEAD RECEPTOR	24 FT STOCK LENGTH
	A294221XX	6" [153mm] DUAL & TRIPLE GLAZED SILL RECEPTOR	24 FT STOCK LENGTH
	A294222XX	6" [153mm] DUAL & TRIPLE GLAZED JAMB & HEAD RECEPTOR	24 FT STOCK LENGTH
	A294321XX	6 3/4" [171mm] TRIPLE GLAZED SILL RECEPTOR	24 FT STOCK LENGTH
	A294322XX	6 3/4" [171mm] DUAL & TRIPLE GLAZED JAMB & HEAD RECEPTOR	24 FT STOCK LENGTH
	EA293001XX	GLASS STOP	24 FT STOCK LENGTH
	EA29400100	VERTICAL INTERMEDIATE REINFORCEMENT	24 FT STOCK LENGTH MILL FINISH
	E9410XX	RECEPTOR DRIVE-ON STOP	24 FT STOCK LENGTH

AVAILABLE FINISHES

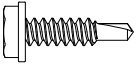
- | | | | | |
|------------------|--------------------|--------------------|------------------|--------------------|
| (00) Mill Finish | (28) Medium Bronze | (41) Clear Class 2 | (42) Dark Bronze | (71) Clear Class 1 |
| (73) Black | (75) Light Bronze | (76) Champagne | (09) Painted | |

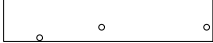
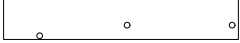
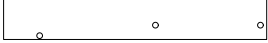
SHAPE	Part No.	DESCRIPTION	Notes
	1476203	EPDM SETTING BLOCK 1" x $\frac{26}{64}$ " x 4"	SOLD PER PIECE
	2250603	EDGE BLOCKING	SOLD PER PIECE
	S290001	FRAME ASSEMBLY SCREW 10-24 x 1 1/2" HEX WASHER HEAD SELF TAPPING	SOLD PER PIECE
	S290004	VENT ANCHOR FASTENER 10-24 x 2" HEX WASHER HEAD SELF TAPPING	SOLD PER PIECE
	S196	END CAP ATTACHMENT SCREW 8 x $\frac{3}{8}$ Pan Head Type A, Stainless Steel	SOLD PER PIECE
	S441	ATTACHMENT OF HOR. MULLION SCREW TO SHEAR BLOCK 10-16 x $\frac{3}{4}$ HEX WASHER HEAD SELF DRILLING	SOLD PER PIECE
	P2918	ANCHOR SLIDE-IN AT RECEPTOR, 6in	SOLD PER PIECE
	P294201	5 1/4" SILL RECEPTOR END CAP	SOLD PER PIECE
	P294211	6" SILL RECEPTOR END CAP	SOLD PER PIECE
	P294321	6 3/4" SILL RECEPTOR END CAP	SOLD PER PIECE

SHAPE	Part No.	DESCRIPTION	Notes
	1342103	EXTERIOR GLAZING GASKET EPDM	500 FEET ROLL
	1343003	PRIME SEAL GASKET EPDM	500 FEET PER ROLL 1000 FEET PER BOX
	1840903	LIGHT GLAZING GASKET 1 1/16in [27mm] DBL GLAZED 1 3/4in [44.5mm] TRPL GLAZED	500 FEET ROLL
	1841003	STANDARD GLAZING GASKET 1in [25.5mm] DBL GLAZED 1 11/16in [43mm] TRPL GLAZED	250 FEET ROLL
	1841103	HEAVY GLAZING GASKET 15/16in [24.5mm] DBL GLAZED 1 5/8in [41.5mm] TRPL GLAZED	500 FEET ROLL
	P6296	FRAME RECEPTOR BULB GASKET	500 FEET ROLL
	P9076	INTERIOR RECEPTOR WEDGE GASKET	500 FEET ROLL
	P290001	PLASTIC WEEP HOLE COVER - BLACK	SOLD PER PIECE
	P290002	PLASTIC WEEP HOLE COVER - WHITE	SOLD PER PIECE
	P290003	VERTICAL SPLIT MULLION GASKET (OPTIONAL)	
	P290005	OPEN CELL BAFFLE 1 1/2" x 3/8" x 1/4"	SOLD PER PIECE
	P290006	BUCKLING CLUB 6in	SOLD PER PIECE
	P290007	SHEAR BLOCK 1in	SOLD PER PIECE
	P290010	2970 & 2990 BULL NOSE MULLION ALIGNMENT CLIP	SOLD PER PIECE
	P290011	2900 FLUSH NOSE MULLION ALIGNMENT CLIP	SOLD PER PIECE
	1476203	EPDM SETTING BLOCK 1" x 26/64" x 4"	SOLD PER PIECE
	P2918-OR	ANCHOR SLIDE-IN AT RECEPTOR, 6in	SOLD PER PIECE

NOTE: Refer to the **PRODUCT DETAILS** document for a complete list of details

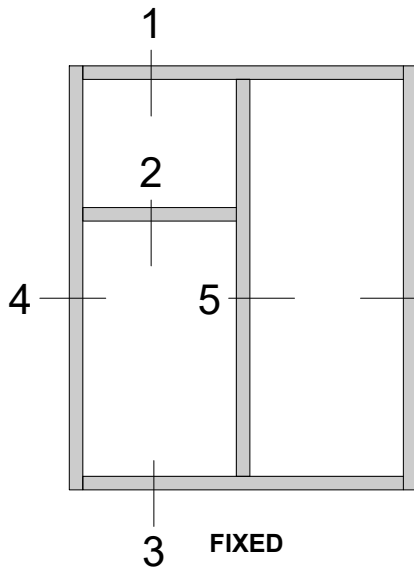

1 HEAD STANDARD

2 INTERMEDIATE HORIZONTAL

3 SILL

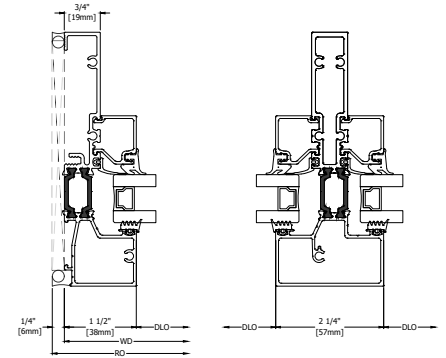
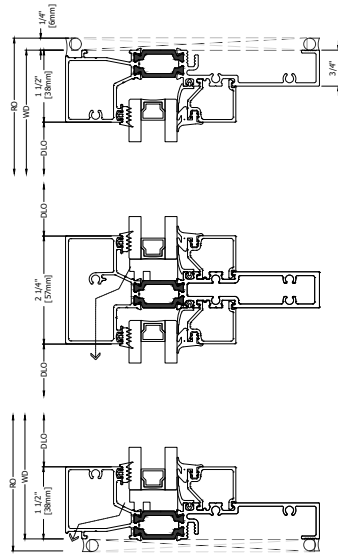

4 JAMB

5 INTERMEDIATE VERTICAL

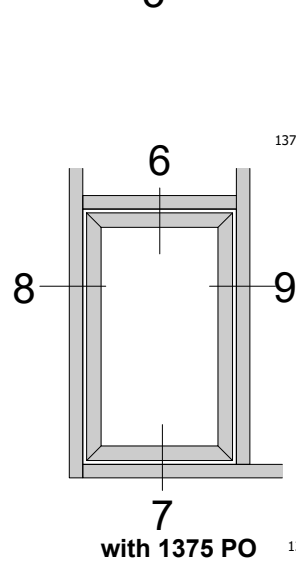

6 1375 PO INSERT VENT AT AHEAD

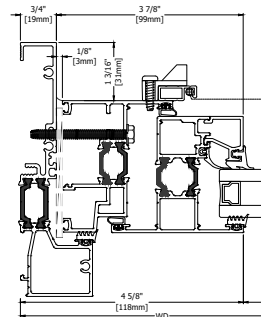
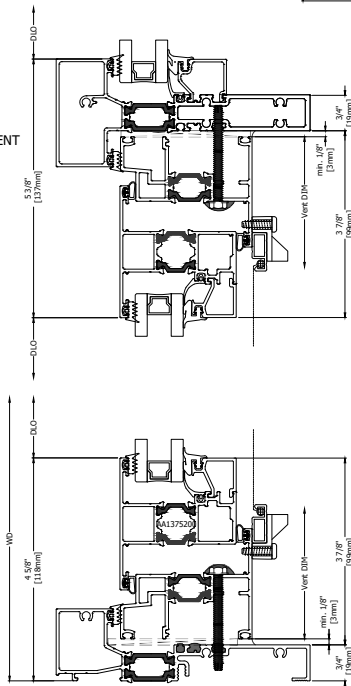

8 1375 PO INSERT VENT AT JAMB

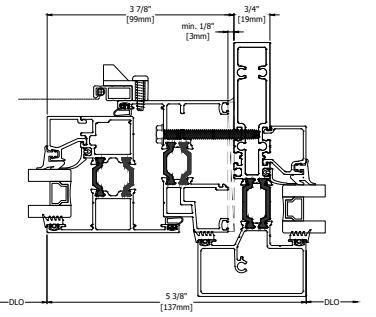

9 1375 PO INSERT VENT AT INTERMEDIATE VERTICAL

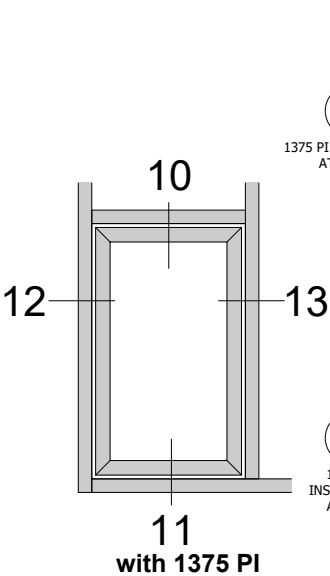

10 1375 PI INSERT VENT AT AHEAD

11 1375 PI INSERT VENT AT SILL

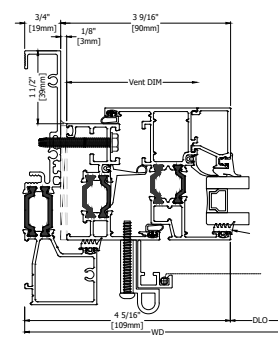
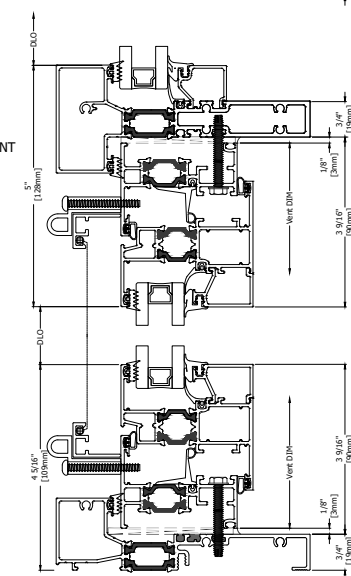

12 1375 PI INSERT VENT AT JAMB

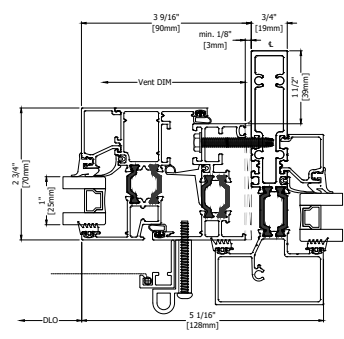

13 1375 PI INSERT VENT AT INTERMEDIATE VERTICAL

NOTE: Refer to the **PRODUCT DETAILS** document for a complete list of details

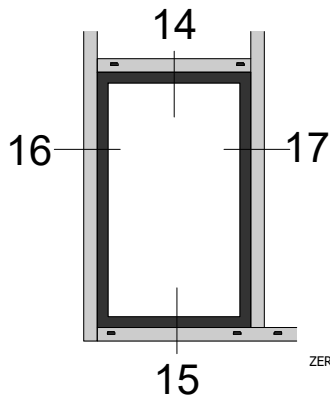

14
5000
ZERO SIGHTLINE VENT
AT HEAD

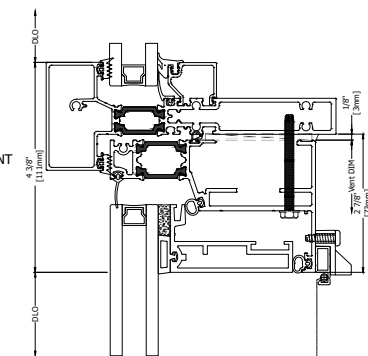

15
5000
ZERO SIGHTLINE VENT
AT SILL

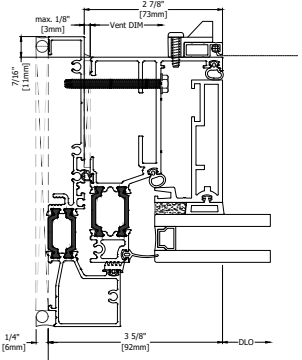
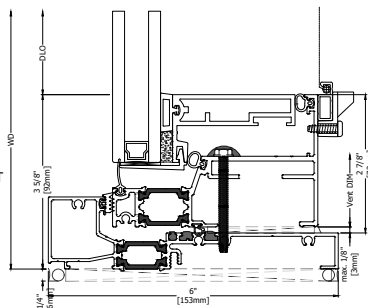

16
5000
ZERO SIGHTLINE VENT
AT JAMB

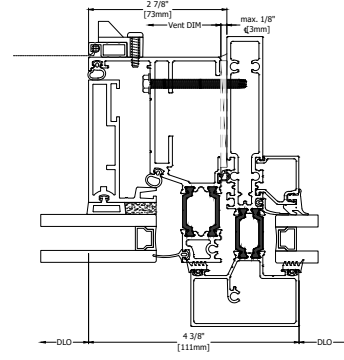

17
5000
ZERO SIGHTLINE VENT
AT INTERMEDIATE VERTICAL

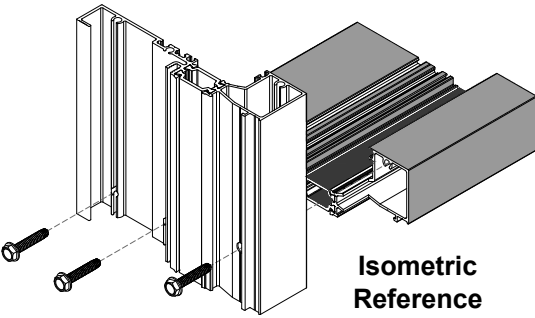
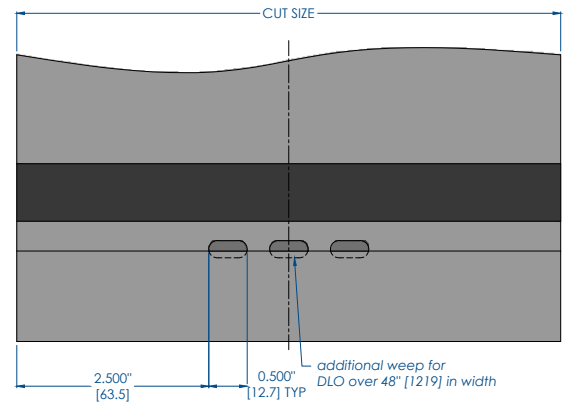
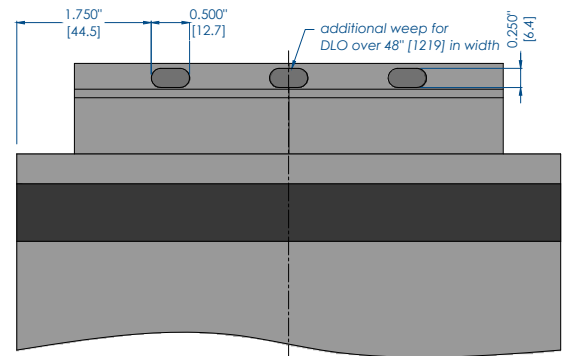
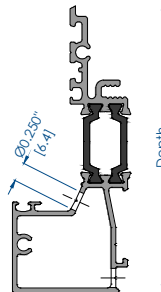
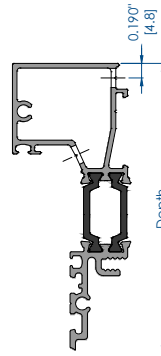
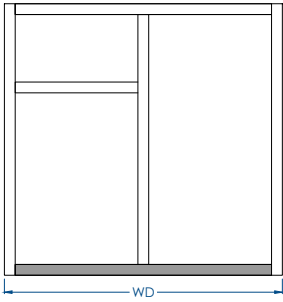

CUT SIZE (90° cut)						
MEMBER	DEPTH	CUT SIZE	'A'	'B'	'C'	'D'
A299201 (DG 5 1/4")	5.289" [134]	WD - 1.5" [25.4]			NA	NA
A299221 (DG 6.00")	6.039" [153]	WD - 1.5" [25.4]			1.375" [34.9]	2.912" [74]
A299301 (TG 6.00")	6.000" [152]	WD - 1.5" [25.4]	0.625" [15.9]	2.163" [54.9]	NA	NA
A299321 (TG 6 3/4")	6.748" [171]	WD - 1.5" [25.4]			1.375" [34.9]	2.912" [74]

A299201 Shown
A299221, A299301, A290321 Similar

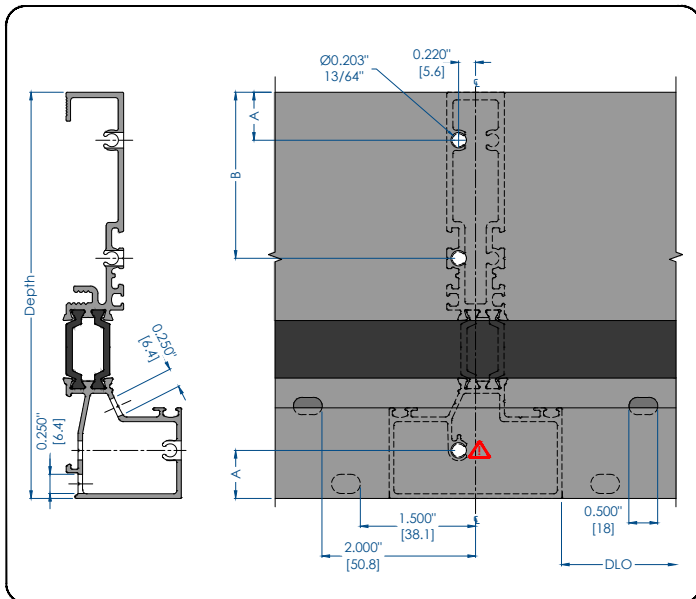

PREP for Vertical Intermediate
using same depth frame & intermediate

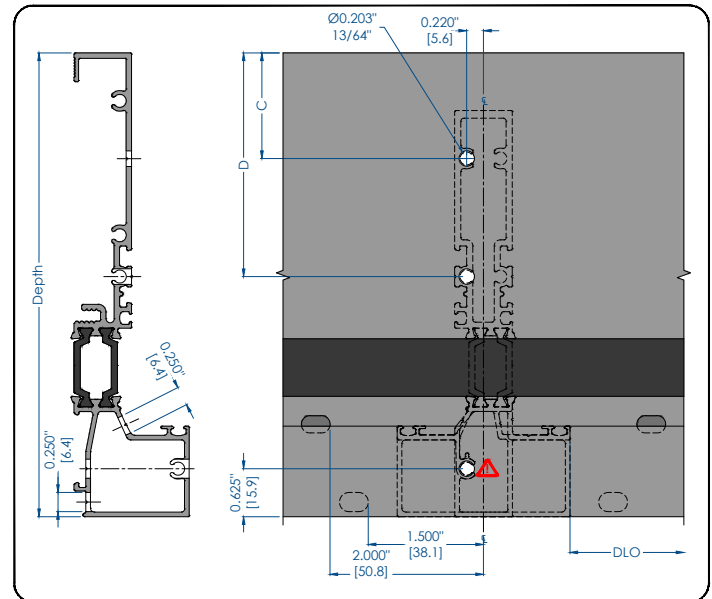

PREP for Vertical Intermediate
using deep frame with shallow intermediate

⚠ DO NOT PREP 'A' FOR FLUSH NOSE INTERMEDIATE:
A290202 A290204 A290302 A290304

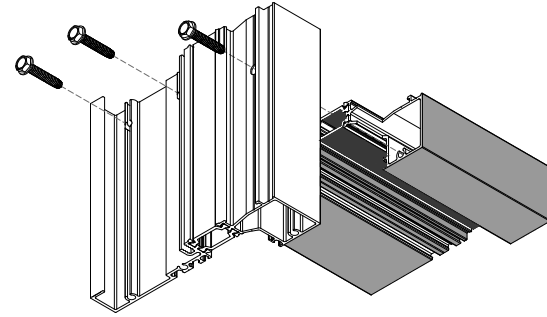
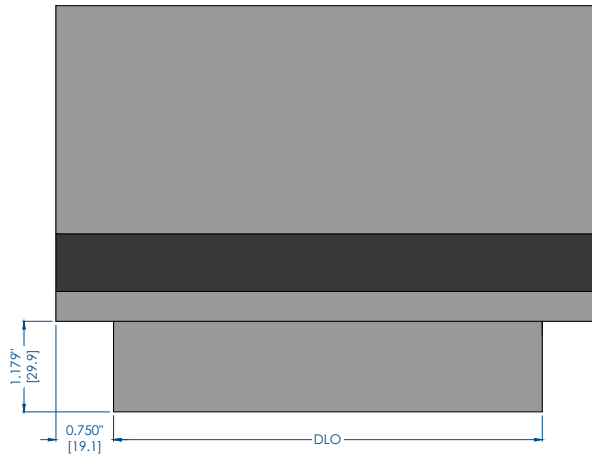
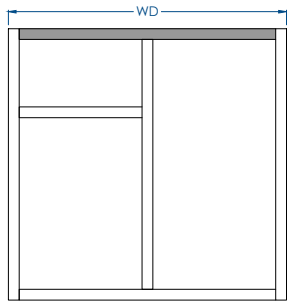

Isometric Reference

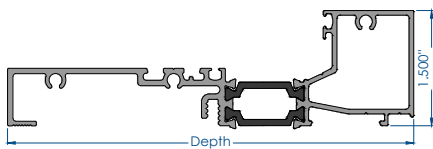

A299201 Shown
A299221, A299301, A290321 Similar

CUT SIZE (90° cut)						
MEMBER	DEPTH	CUT SIZE	'A'	'B'	'C'	'D'
A299201 (DG 5 1/2")	5.289" [134]	WD - 1.5" [25.4]			NA	NA
A299221 (DG 6.00")	6.039" [153]	WD - 1.5" [25.4]	0.625" [15.9]	2.163" [54.9]	1.375" [34.9]	2.912" [74]
A299301 (TG 6.00")	6.000" [152]	WD - 1.5" [25.4]			NA	NA
A299321 (TG 6 3/4")	6.748" [171]	WD - 1.5" [25.4]			1.375" [34.9]	2.912" [74]

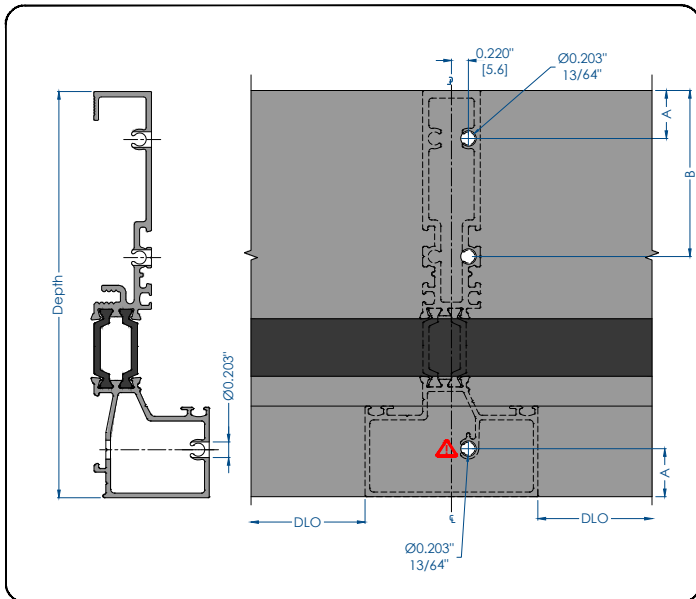

PREP for Vertical Intermediate
using same depth frame & intermediate

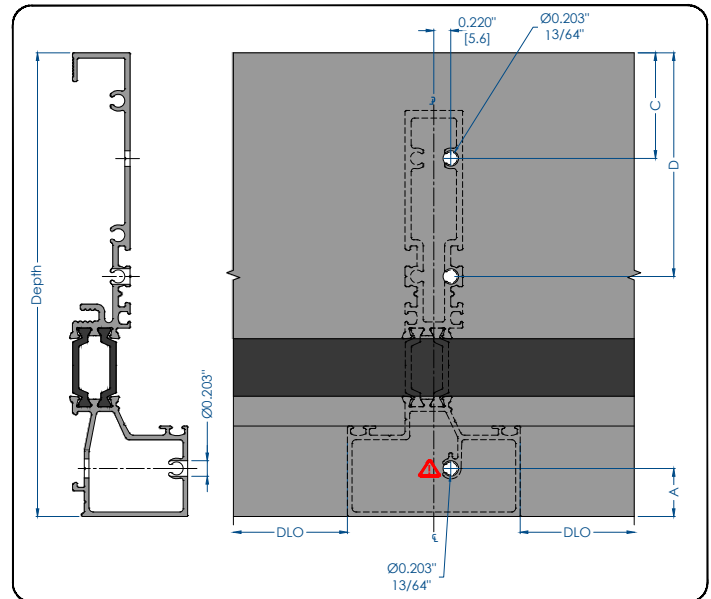

PREP for Vertical Intermediate
using deep frame with shallow intermediate

⚠ DO NOT PREP 'A' FOR FLUSH NOSE INTERMEDIATE:
A290202 A290204 A290302 A290304

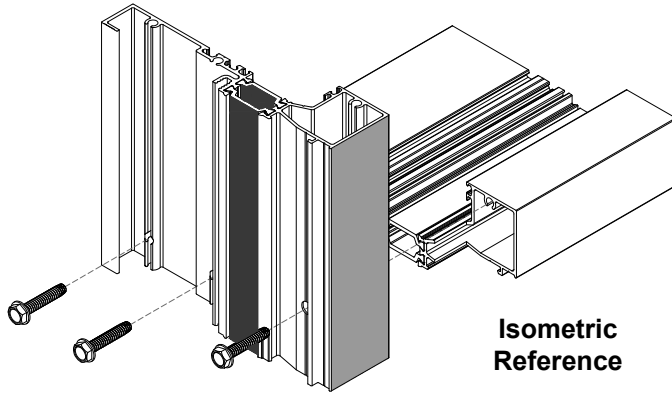
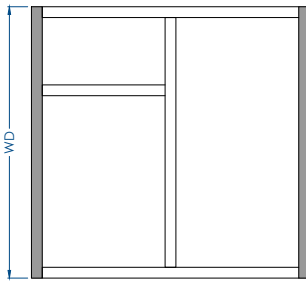

Isometric Reference

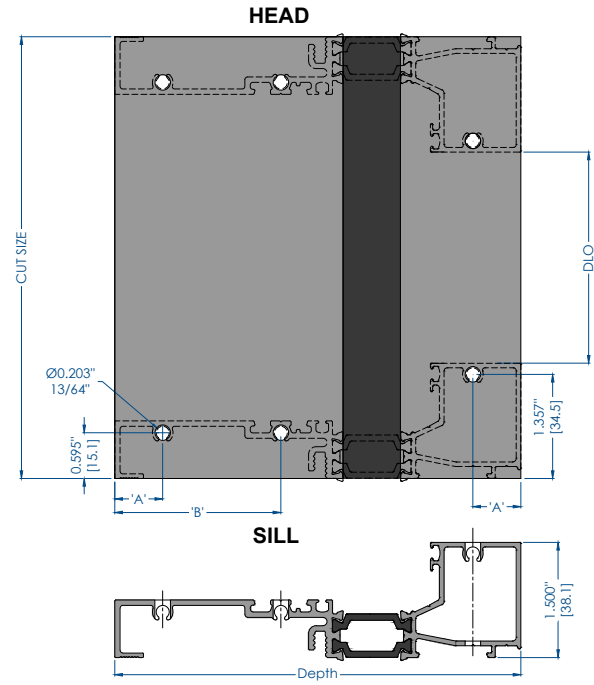

A299201 Shown
A299221, A299301, A299321 Similar

CUT SIZE (90° cut)						
MEMBER	DEPTH	CUT SIZE	'A'	'B'	'C'	'D'
A299201 (DG 5 1/4")	5.289" [134]	WD	0.625" [15.9]	2.163" [54.9]	NA	NA
A299221 (DG 6.00")	6.039" [153]	WD			1.375" [34.9]	2.912" [74]
A299301 (TG 6.00")	6.000" [152]	WD			NA	NA
A299321 (TG 6 3/4")	6.748" [171]	WD			1.375" [34.9]	2.912" [74]

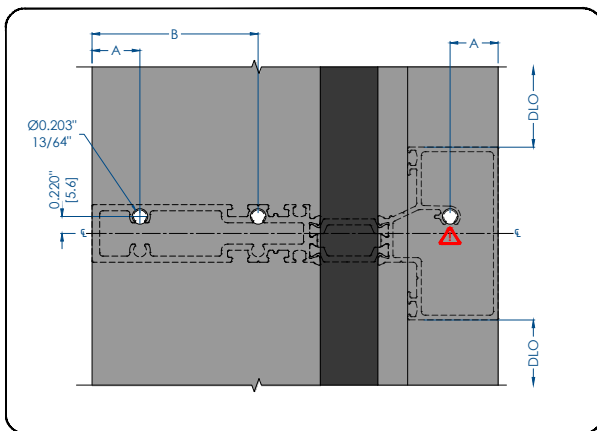

Optional prep for Horizontal Intermediate
using same depth frame & intermediate

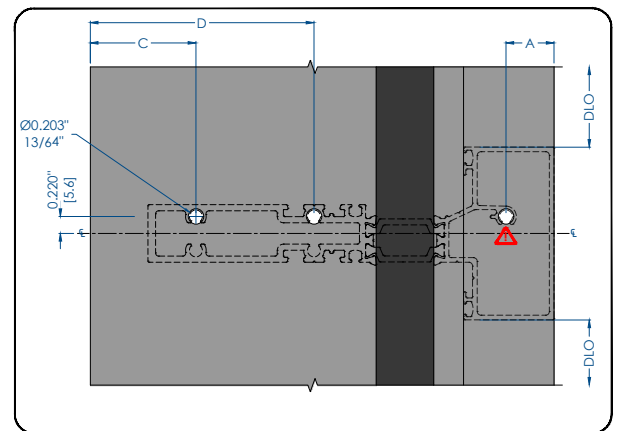

Optional prep for Horizontal Intermediate
using deep frame with shallow intermediate

⚠ DO NOT PREP 'A' FOR FLUSH NOSE INTERMEDIATE:
A290202 A290204 A290302 A290304

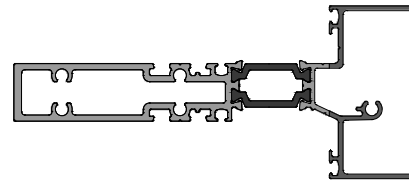
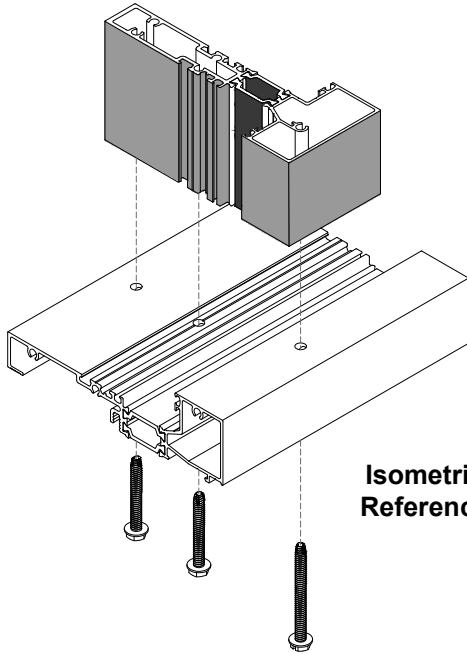
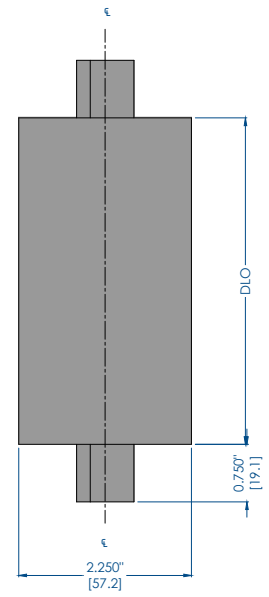
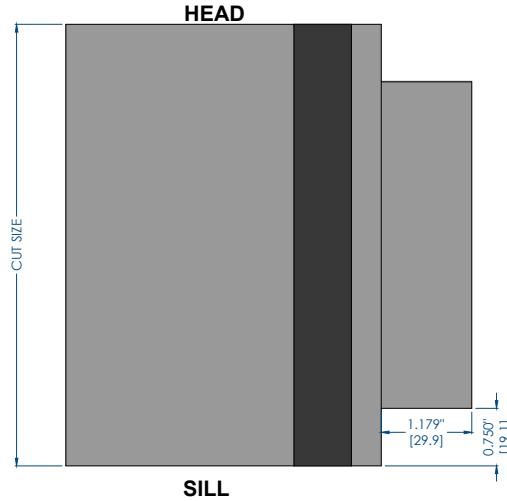
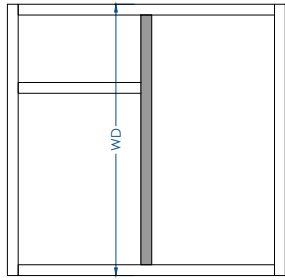

A299201 Shown
A299221, A299301, A290321 Similar

CUT SIZE (90° cut)				
MEMBER	DEPTH	CUT SIZE	'SA'	'SB'
(DG 5 1/2") A299202	5.289" [134]	WD - 1.5" [25.4]	0.325" [8.3]	1.537" [39]
(DG 6.00") A299222	6.039" [153]	WD - 1.5" [25.4]	1.040" [26.4]	2.250" [57]
(TG 6.00") A299302	6.000" [152]	WD - 1.5" [25.4]	0.325" [8.3]	1.537" [39]
(TG 6 3/8") A299322	6.748" [171]	WD - 1.5" [25.4]	1.040" [26.4]	2.250" [57]

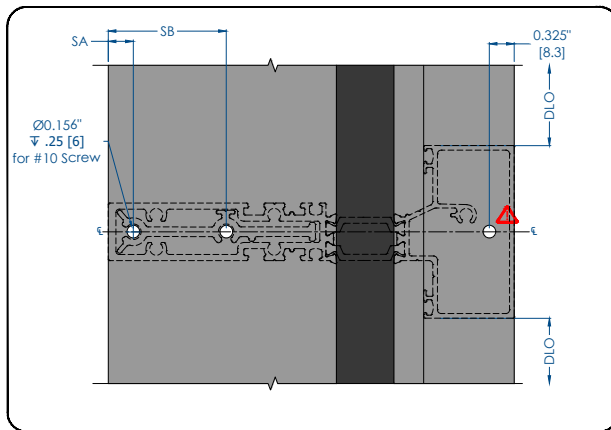

Optional prep for Horizontal Intermediate
using same depth frame & intermediate

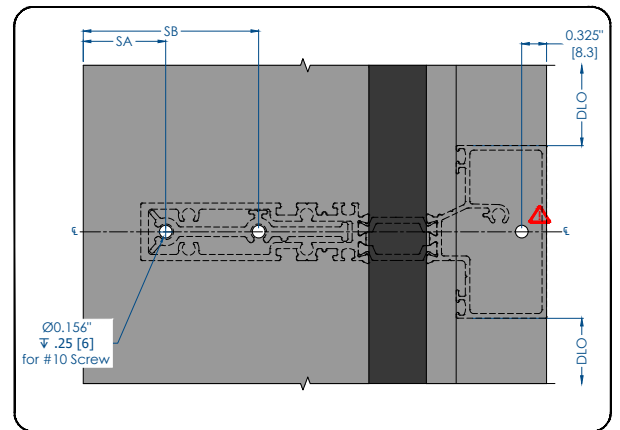

Optional prep for Horizontal Intermediate
using deep frame with shallow intermediate

! DO NOT PREP 'A' FOR FLUSH NOSE INTERMEDIATE:
A290202 A290204 A290302 A290304

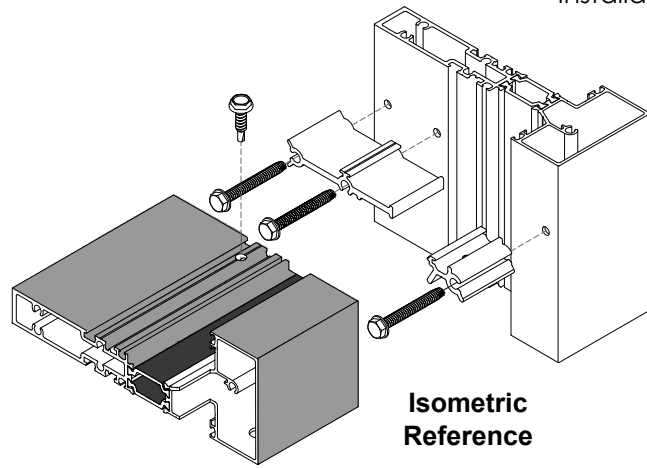
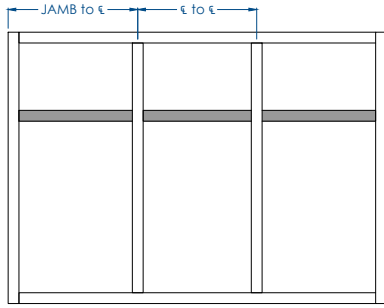

CUT SIZE (90° cut)			
MEMBER	DEPTH	CUT SIZE	'A'
A299202 (DG 5 1/2")	5.289" [109]	JAMB to CL - 1.125" [28.6] CL to CL - 0.750" [19.1]	2.163" [54.9]
A299222 (DG 6.00")	6.039" [128]		2.912" [74]
A299302 (TG 6.00")	6.000" [127]	JAMB to CL - 1.125" [28.6] CL to CL - 0.750" [19.1]	2.163" [54.9]
A299322 (TG 6 3/4")	6.748" [146]		2.912" [74]

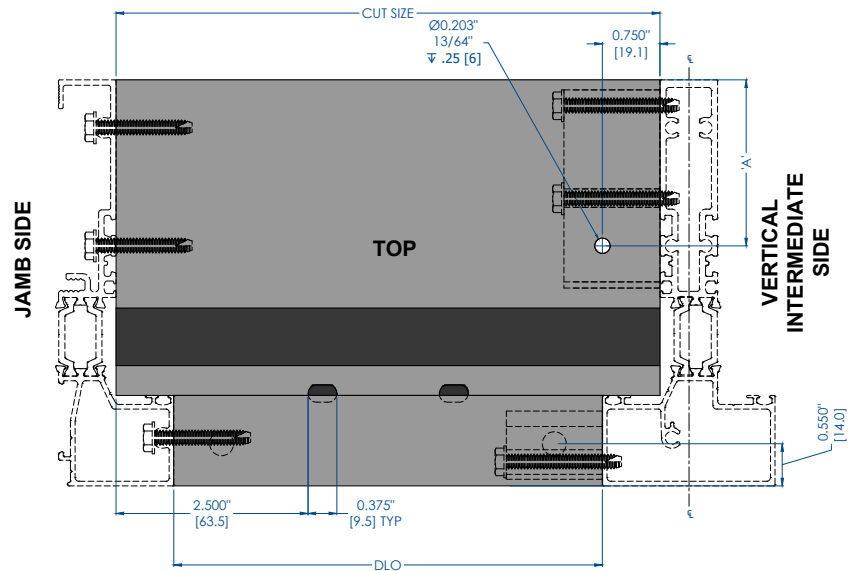
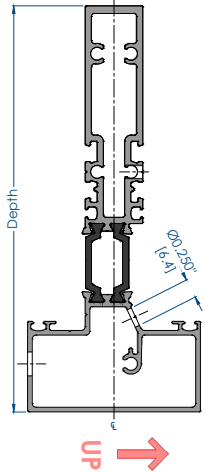

A299202 Shown
A299204, A299302, A299304 Similar

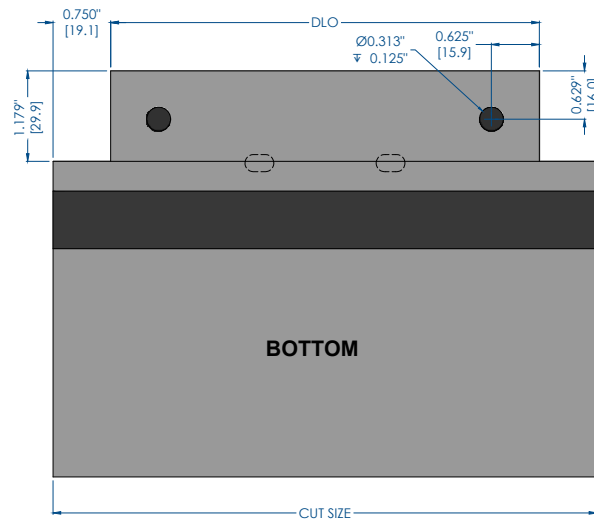
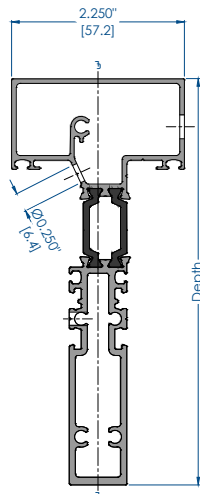

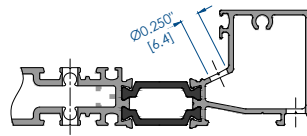
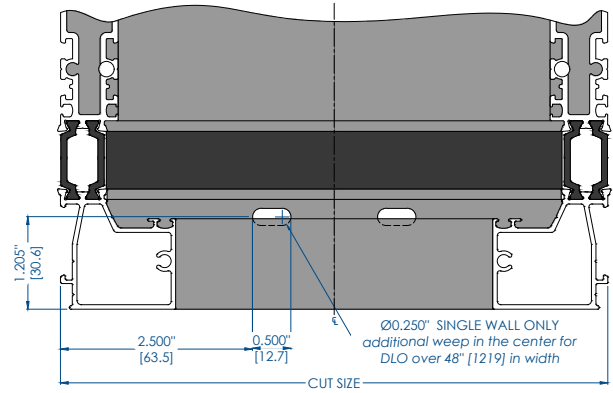
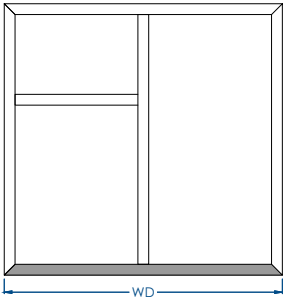

A299205 Shown
A299225, A299305, A299325
Similar

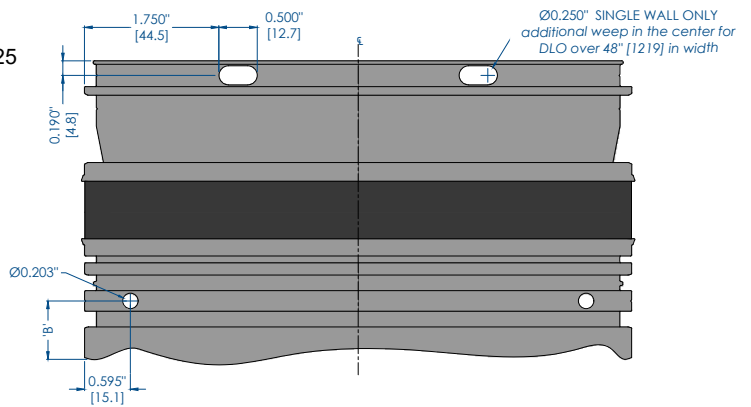
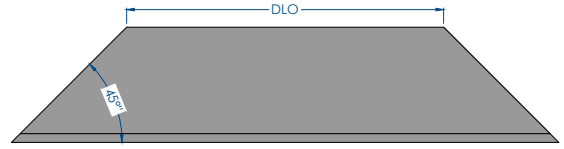

CUT SIZE (45° miter cut)							
MEMBER	DEPTH	CUT SIZE	'MF'	'A'	'B'	'C'	'D'
(DG 5 1/2") A299205	5.289" [134]	WD				NA	NA
(DG 6.00") A299225	6.039" [153]	WD	1.304" [33]	0.625" [15.9]	2.163" [54.9]	1.375" [34.9]	2.912" [74]
(TG 6.00") A299305	6.000" [152]	WD				NA	NA
(TG 6 3/4") A299325	6.748" [171]	WD				1.375" [34.9]	2.912" [74]

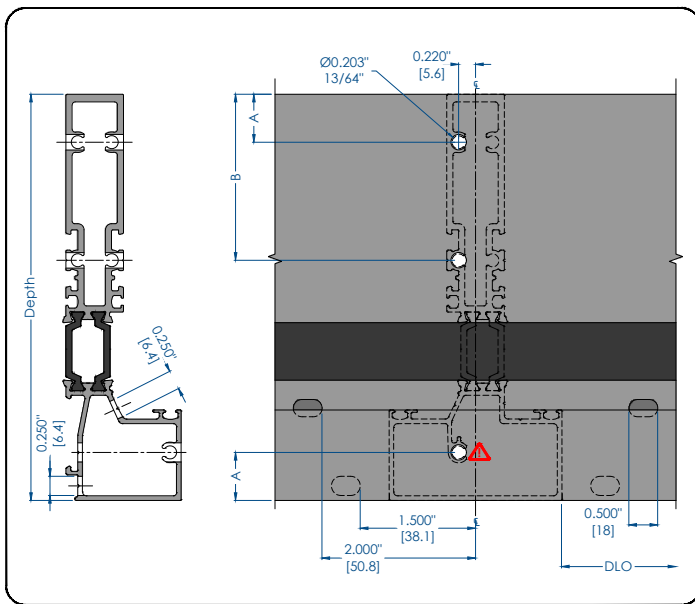

PREP for Vertical Intermediate
using same depth frame & intermediate

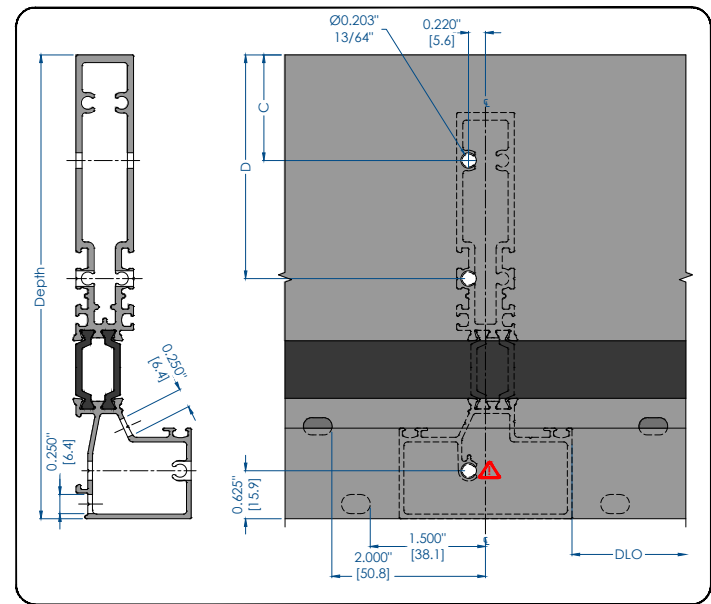

PREP for Vertical Intermediate
using deep frame with shallow intermediate

⚠ DO NOT PREP 'A' FOR FLUSH NOSE INTERMEDIATE:
A290202 A290204 A290302 A290304

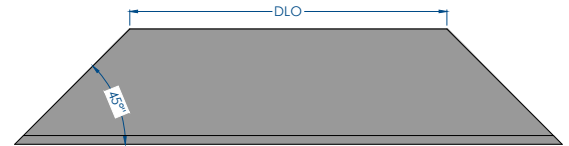
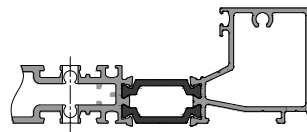
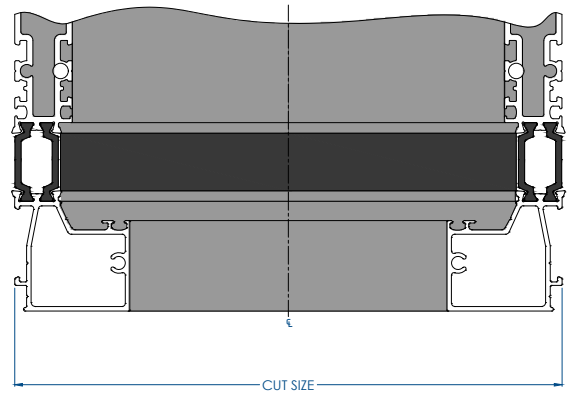
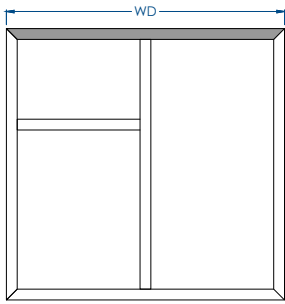

A299205 Shown
A299225, A299305, A299325
Similar

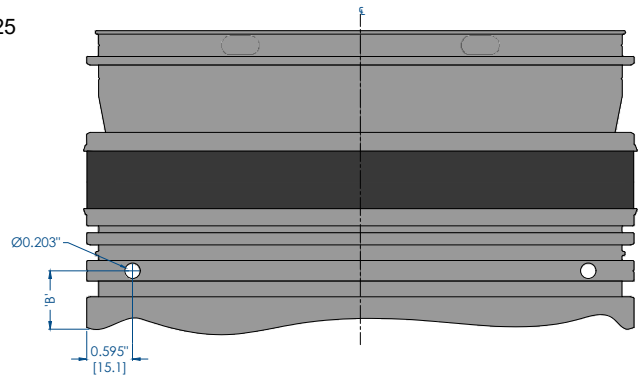

CUT SIZE (45° miter cut)							
MEMBER	DEPTH	CUT SIZE	'MF'	'A'	'B'	'C'	'D'
(DG 5 1/2") A299205	5.289" [134]	WD				NA	NA
(DG 6.00") A299225	6.039" [153]	WD	1.304" [33]	0.625" [15.9]	2.163" [54.9]	1.375" [34.9]	2.912" [74]
(TG 6.00") A299305	6.000" [152]	WD				NA	NA
(TG 6 3/4") A299325	6.748" [171]	WD				1.375" [34.9]	2.912" [74]

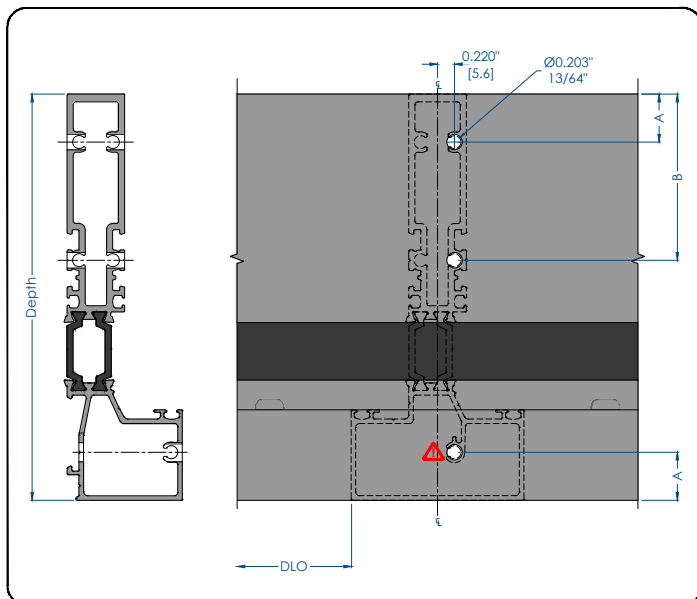

PREP for Vertical Intermediate
using same depth frame & intermediate

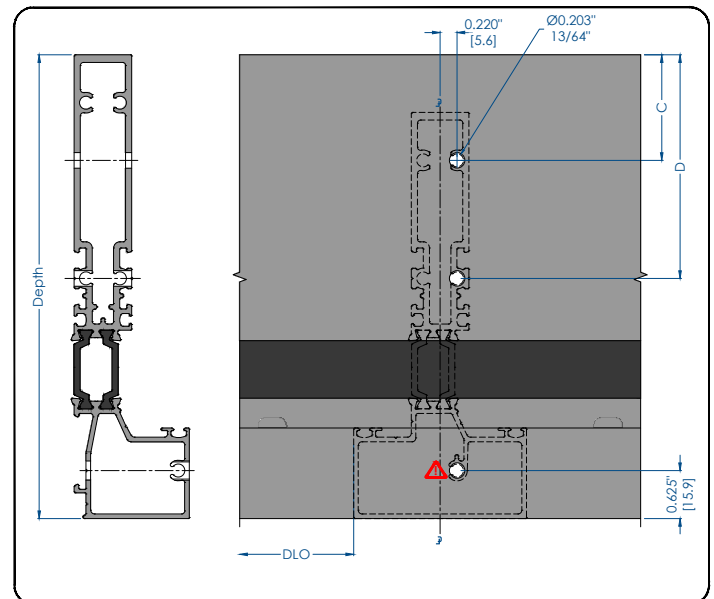

PREP for Vertical Intermediate
using deep frame with shallow intermediate

⚠ DO NOT PREP 'A' FOR FLUSH NOSE INTERMEDIATE:
A290202 A290204 A290302 A290304

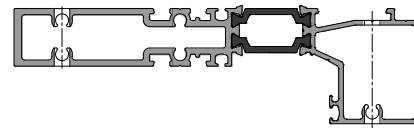
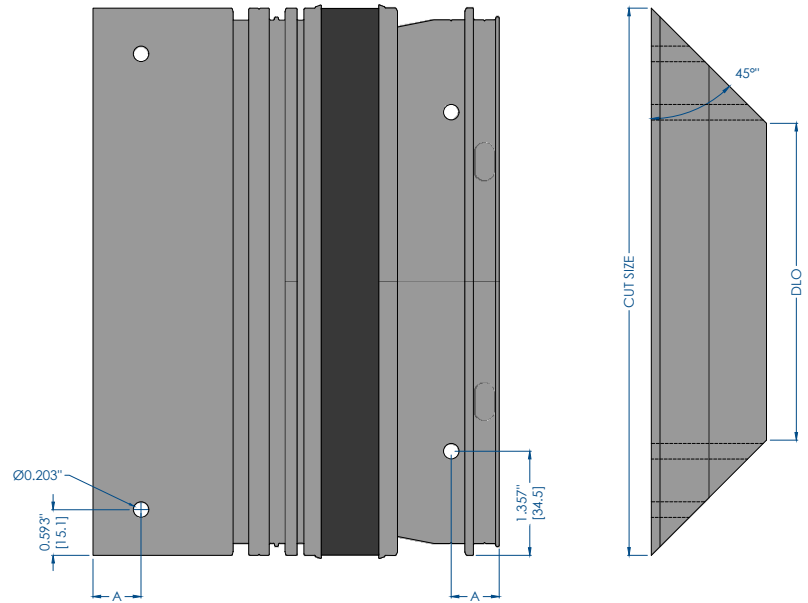
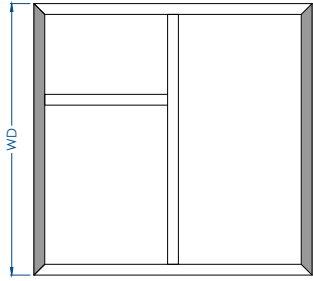

A299205 Shown
A299225, A299305, A299325
Similar

CUT SIZE (45° miter cut)							
MEMBER	DEPTH	CUT SIZE	'MF'	'A'	'B'	'C'	'D'
(DG 5 1/4") A299205	5.289" [134]	WD				NA	NA
(DG 6.00") A299225	6.039" [153]	WD	1.304" [33]	0.625" [15.9]	2.163" [54.9]	1.375" [34.9]	2.912" [74]
(TG 6.00") A299305	6.000" [152]	WD				NA	NA
(TG 6 3/4") A299325	6.748" [171]	WD				1.375" [34.9]	2.912" [74]

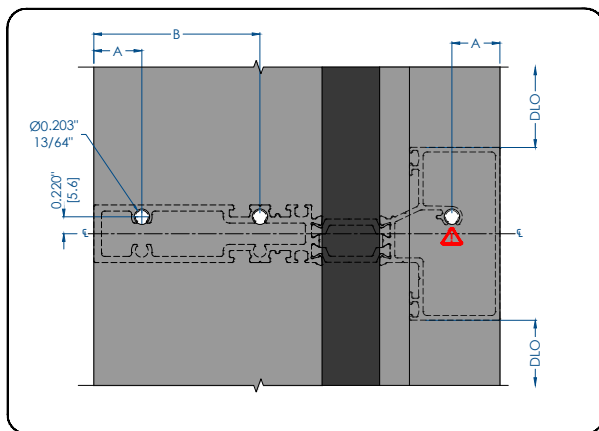

Optional prep for Horizontal Intermediate
using same depth frame & intermediate

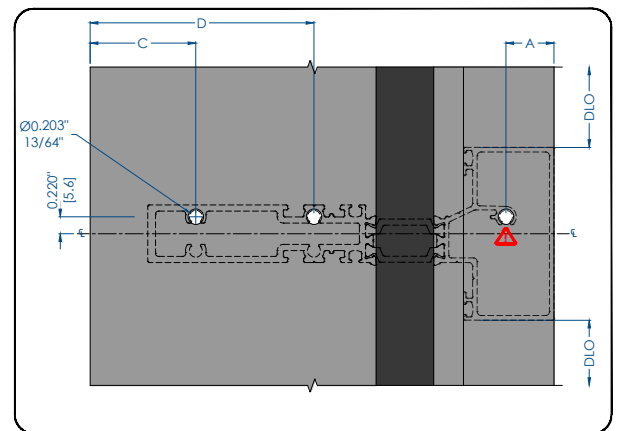

Optional prep for Horizontal Intermediate
using deep frame with shallow intermediate

DO NOT PREP 'A' FOR FLUSH NOSE INTERMEDIATE:
A290202 A290204 A290302 A290304

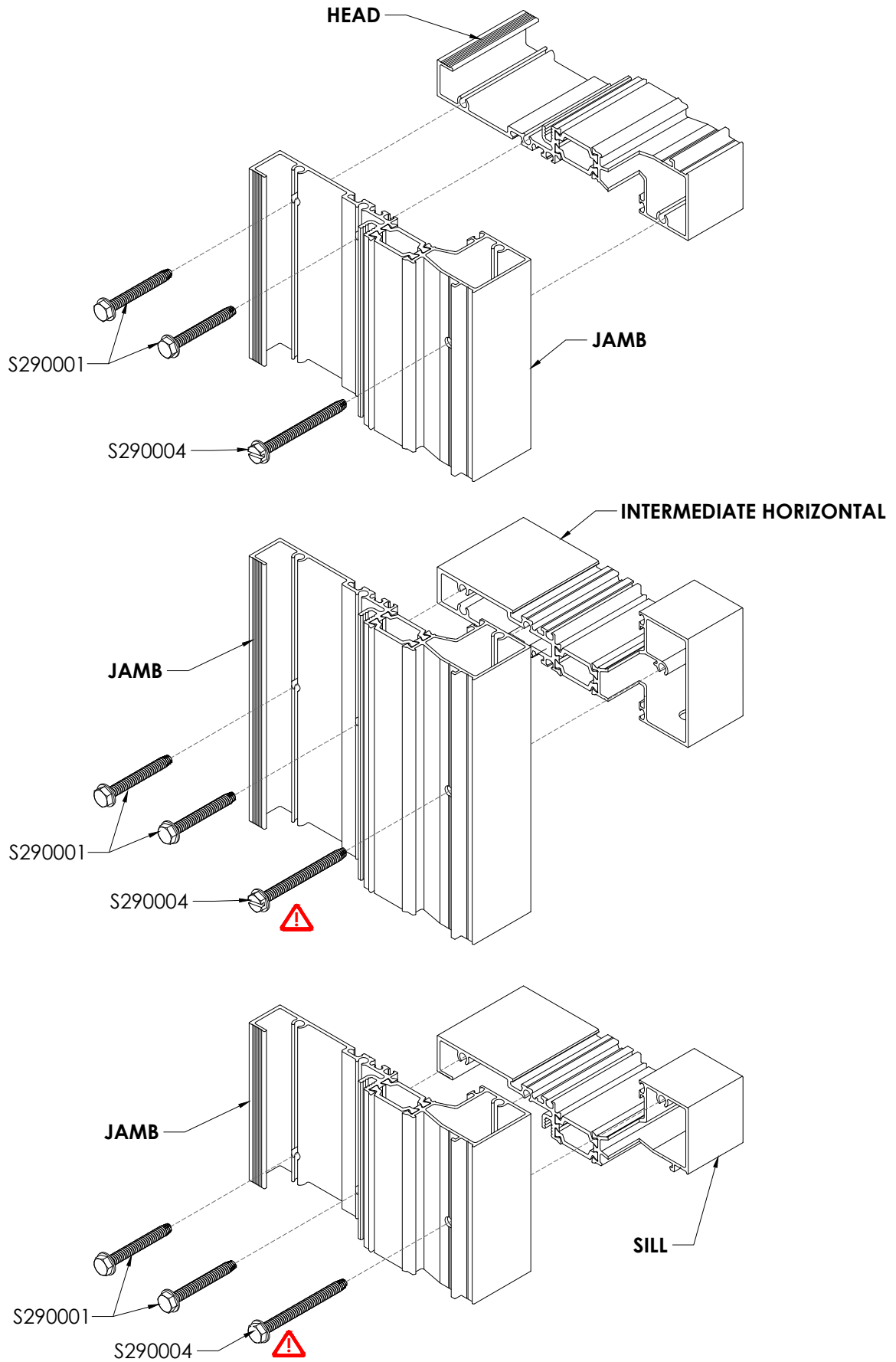

 Cap Seal Screw Head

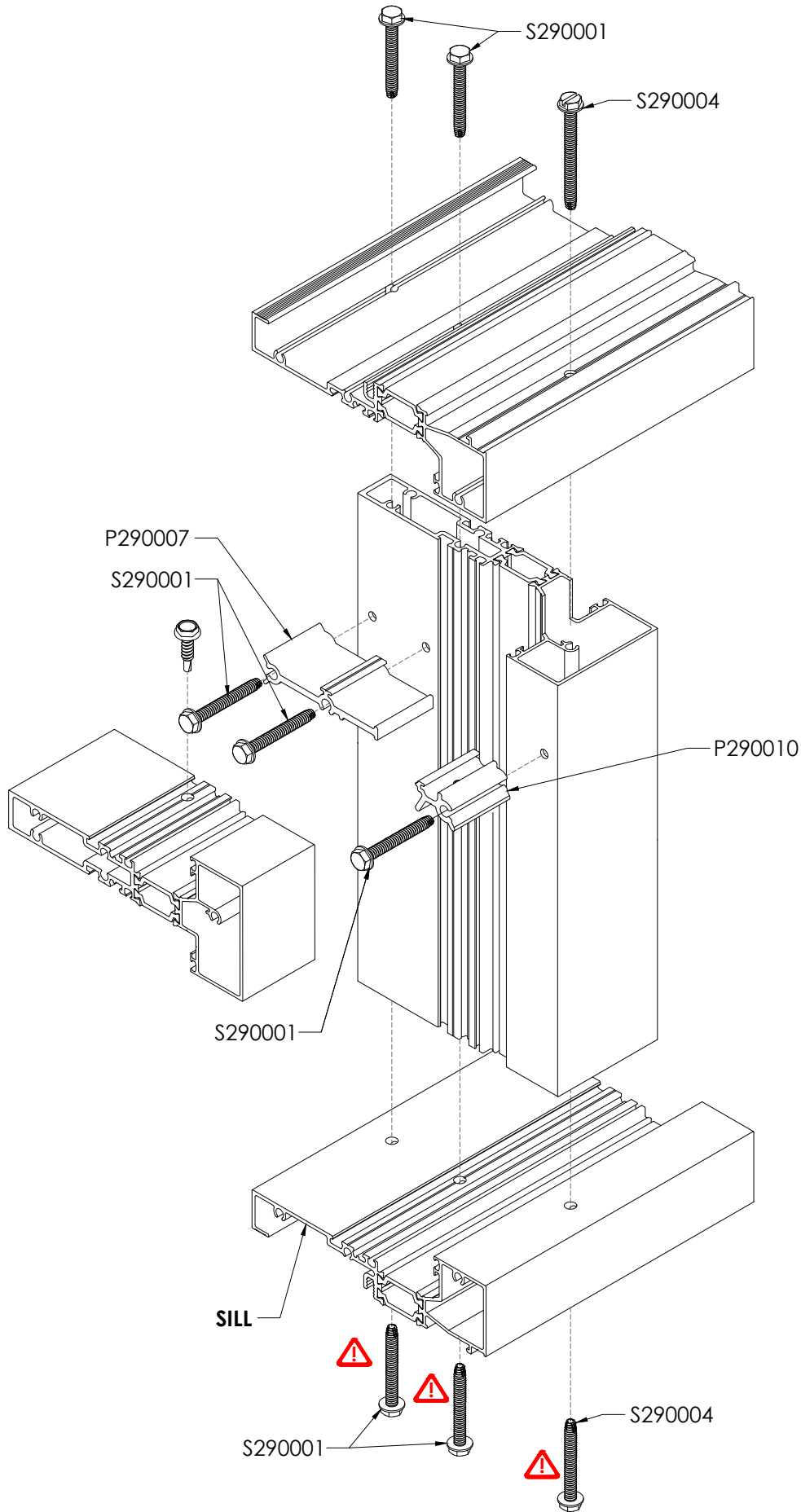

 Cap Seal Screw Head

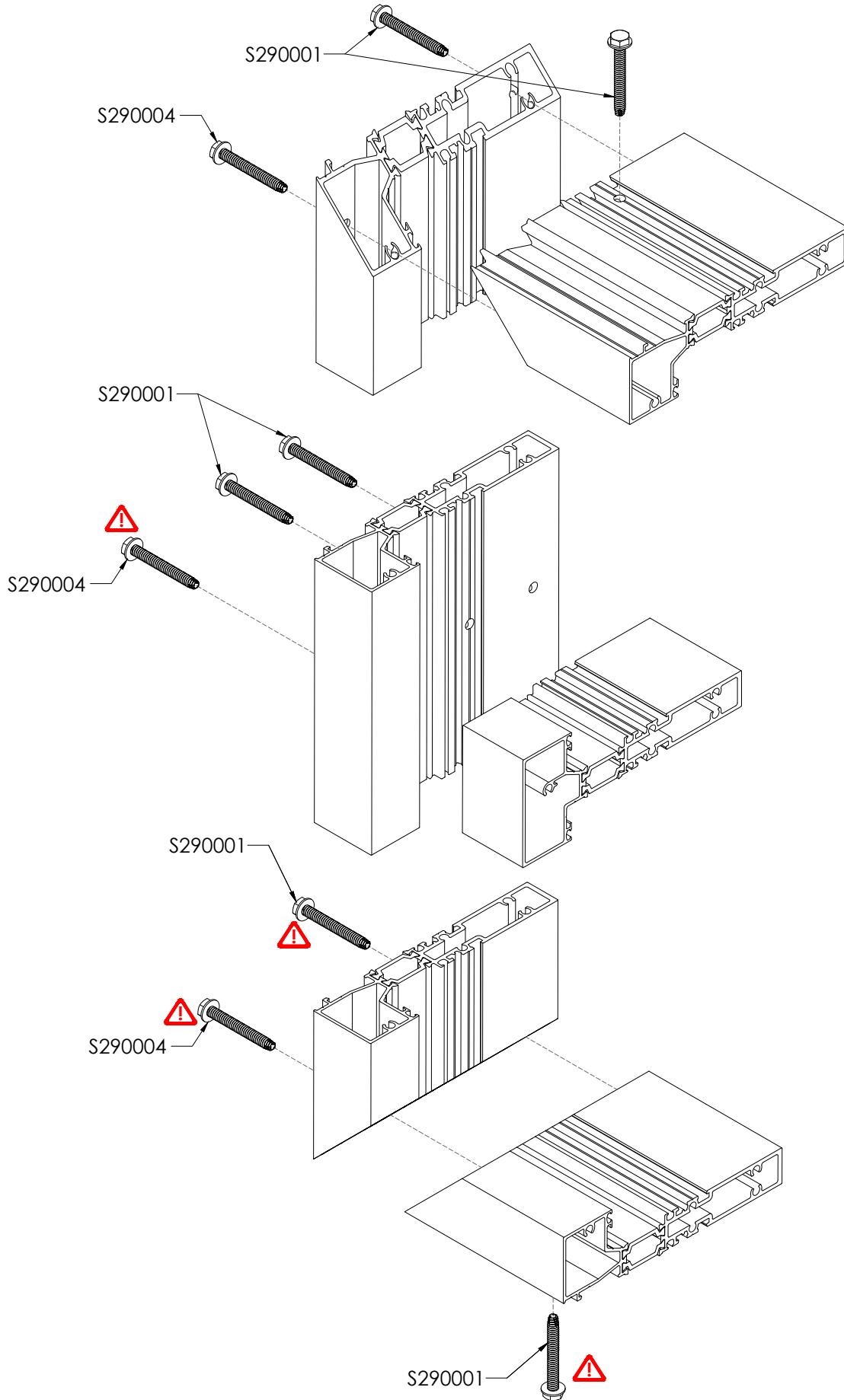

 Cap Seal Screw Heads

STEP 1

SILL & HEAD TO JAMB ASSEMBLY

- a. De-bur and clean all the mating surfaces using IPA 2 method.
- b. Apply sealant to the both ends of the profile. **See FIG 1.**
- c. Pump the sealant across the gutter area slightly higher than the voids in section profile. **See FIG 2.**
- d. Carefully set the vertical section into the sill lining up the assembly holes and installing appropriate fasteners.
- e. Check to ensure the exterior leg is flush with the adjacent sections. Loosen the screws and readjust if necessary.
- f. Using a tooling stick (popsicle stick) tool all the excess sealant on the interior portion of the corner flat to the horizontal section.
- g. Tool the back of the vertical and sill section in the the manner being sure all the section voids are sealed.

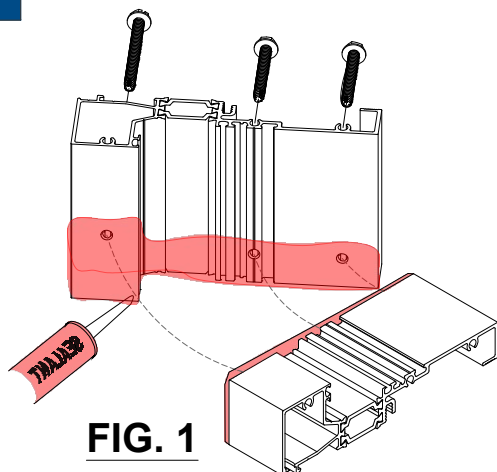

FIG. 1

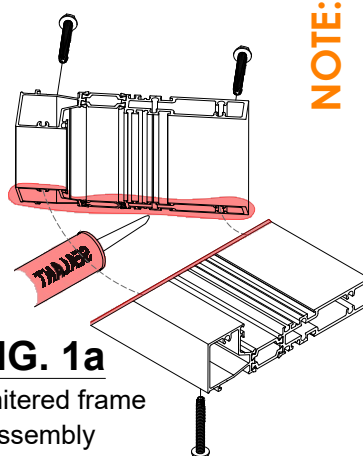

FIG. 1a
45° mitered frame assembly

NOTE: STRAP ANCHORS must be pre-inserted prior to frame assembly. See Strap Anchor Assembly instructions.

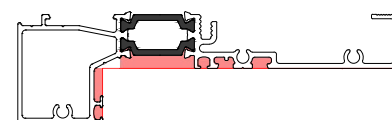

FIG. 2

STEP 2

INTERMEDIATE MULLION TO PERIMETER FRAME ASSEMBLY

- a. Determine the location of vertical intermediate by using a cut off piece.
- b. De-bur and clean all the mating surfaces using IPA 2 method.
- c. Apply sealant to the both ends of the profile. **See FIG 4**
- d. Pump the sealant across the gutter area slightly higher than the voids in section profile. **See FIG 4.**
- e. Carefully set the vertical section onto the sill lining up the assembly holes and installing appropriate fasteners and lock screw. **See FIG 4.**
- f. Check to ensure the exterior leg is flush with the adjacent sections. Loosen the screws and readjust if necessary.
- g. Cap seal screw heads.
- h. Using a tooling stick (popsicle stick) tool all the excess sealant on the interior portion of the corner flat to the horizontal section. **See FIG 5.**

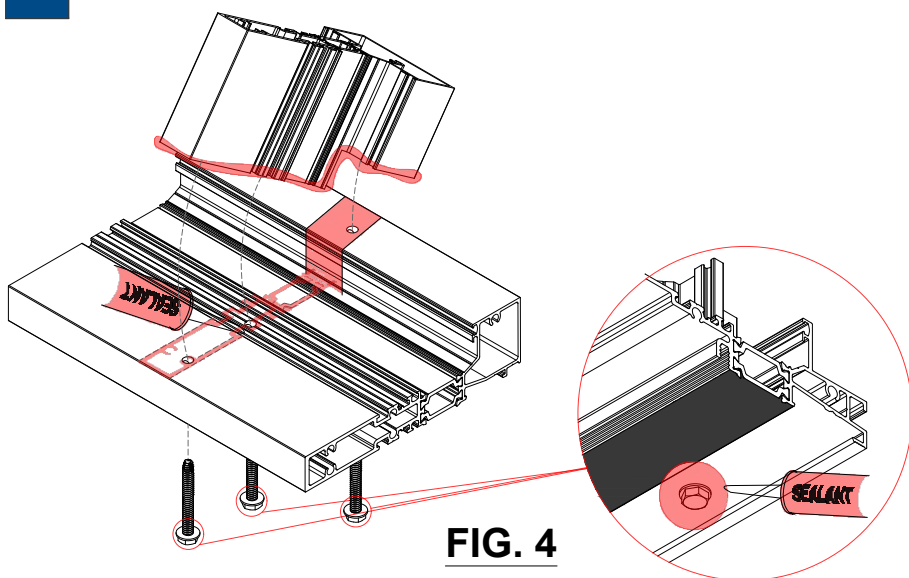

FIG. 4

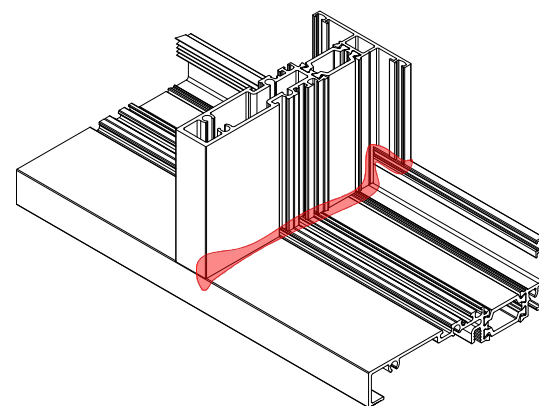

FIG. 5

STEP 1

- Install Shear Block using appropriate fastener listed on INTERMEDIATE MULLION COMPONENTS. **See FIG 2**
- Apply sealant to the both ends of the profile. **See FIG 2.**
- ENSURE horizontal mullions are oriented and assembled with gutter facing upward. **See FIG 3**
- Check to ensure the exterior leg is flush with the adjacent sections. Loosen the screws and readjust if necessary.
- Using a tooling stick (popsicle stick) tool all the excess sealant on the interior portion of the corner flat to the horizontal section.

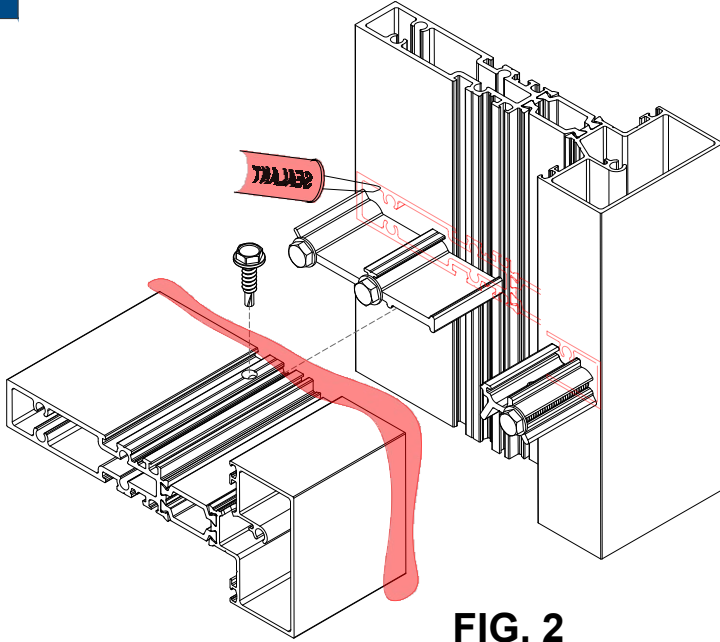

FIG. 2

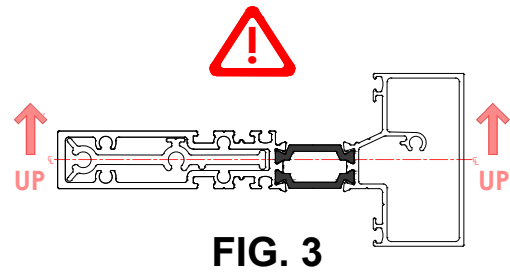

FIG. 3

STEP 2

INTERMEDIATE VERTICAL MULLION TO HORIZONTAL MULLION ASSEMBLY

- Carefully set the horizontal section onto the shear block lining up the assembly holes and match drill pilot hole for #10 Screw through the Shear Block. **See FIG 4**
- Using $\frac{3}{32}$ " Hex Key Lock tighten the set screw between vertical and horizontal mullions. **See FIG 5**

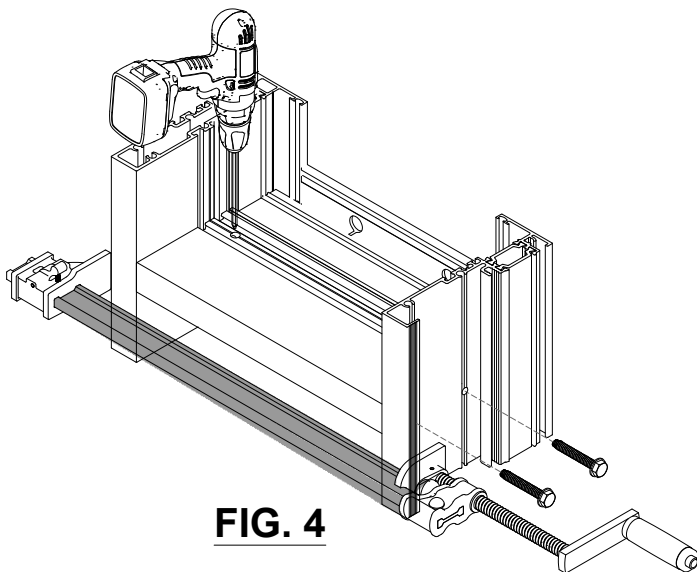

FIG. 4

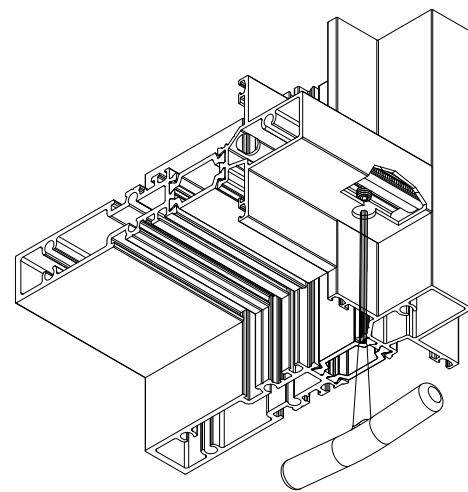

FIG. 5

STEP 1

OPTIONAL STRAP ANCHOR ASSEMBLY

- Refer to approved shop drawings to determine whether the application requires Strap Anchors.
- Pre slide Strap Anchors into the frame and assemble frames as per FRAME ASSEMBLY Instructions. **See FIG 1. & FIG. 3.**
- Position Strap anchors as per approved Shop Drawings along the frame. To prevent the movement of Strap Anchors crimp from both sides using flat head screw driver. **See FIG 2.**

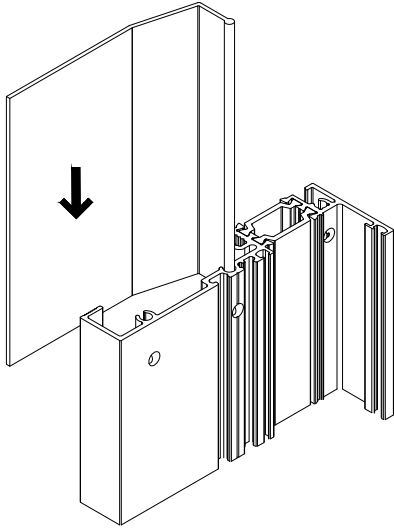

FIG. 1

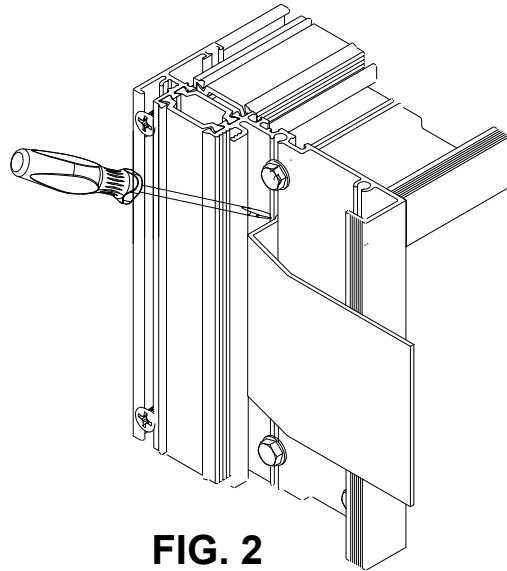

FIG. 2

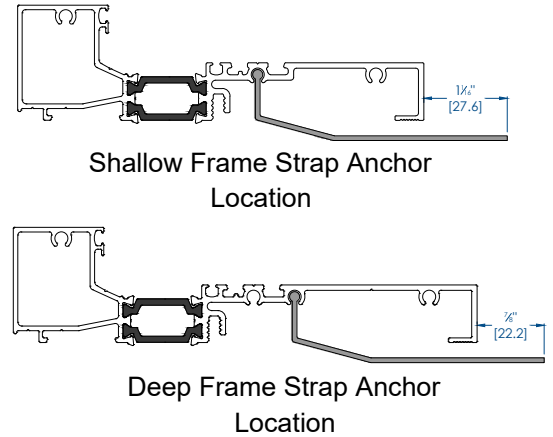

FIG. 3

STEP 2

OPTIONAL MULLION REINFORCEMENT

- Refer to approved shop drawings to determine whether the application required optional reinforcement.
- Full length reinforcement is required, cut reinforced same as vertical mullion.
- Slide the reinforcement into the vertical mullion from one end. **See FIG 4.**
- Using V-Groove indicator drill no larger than #12 pilot holes through one side of the vertical mullion and reinforcement at 16" O.C. or according to project specifications. **See FIG 5.**
- Attach reinforcement using #10 Fasteners. **See FIG 5.**

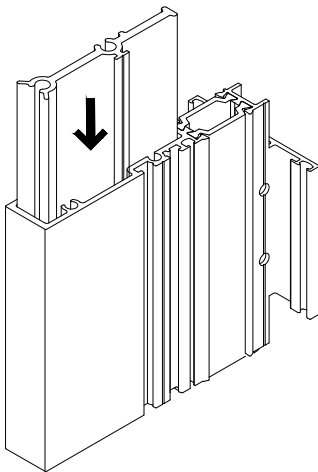

FIG. 4

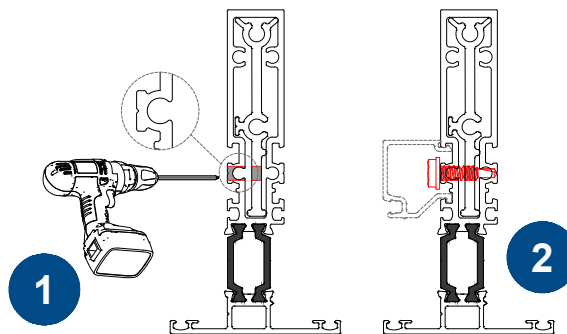

FIG. 5

STEP 1

- Determine anchoring method as per approved shop drawings and establish exterior/interior reference lines. Use the established reference points to determine the installation points for each window opening around the perimeter.
- Ensure the rough opening is 1/2" larger than the window.
- For window frames assembled with 45° frame cuts the rough opening must be 3/4" larger than the window.
- Verify structure framing is plumb, straight.

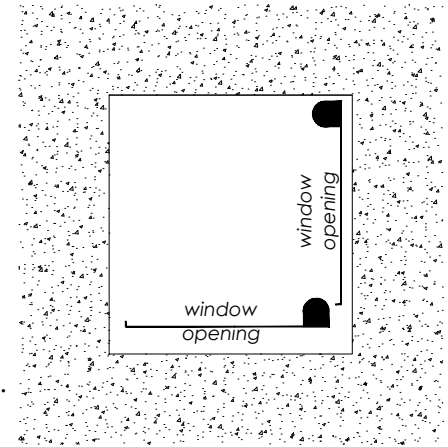

FIG. 1

STEP 2

ANCHORING THROUGH THE FRAME

- FASTENERS MUST NOT EXCEED # 12 size.
- Drill clearance holes using V-groove as a guide. **See FIG 2.**
- Drill location to be 3" from the corner of the frames and maximum 18" O.C. **See FIG 4.**
- Refer to approved shop drawings to determine fastener spacing.
- Shim solidly between window and building substrate. **See FIG 3.**
- Fasten with appropriate screw, DO NOT OVER-TORQUE the anchoring fasteners. **See FIG 3. and FIG 4.**
- Clean perimeter of the frame where seal will be applied using IPA 2 METHOD.
- Apply Interior/Exterior seal around the frame and tool.

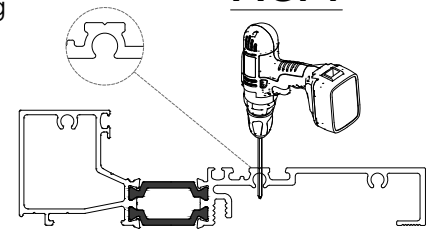

FIG. 2

STEP 3

ANCHORING USING STRAP ANCHORS

- Refer to OPTIONAL STRAP ANCHOR ASSEMBLY and approved shop drawing to locate STRAP ANCHORS.
- Shim solidly between window and building substrate. **See FIG 3.**
- Fasten with appropriate screw. **See FIG 3.**
- Clean perimeter of the frame where seal will be applied using IPA 2 METHOD
- Apply Interior/Exterior seal around the frame and tool.

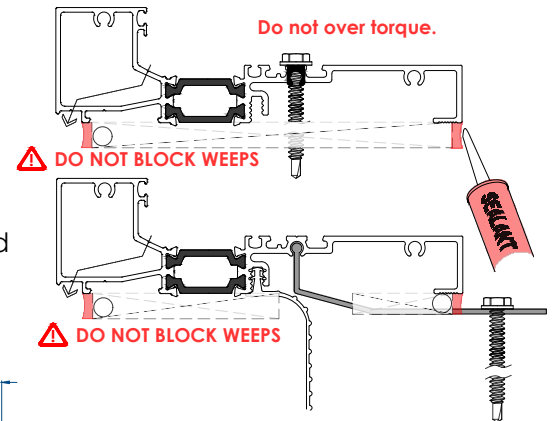
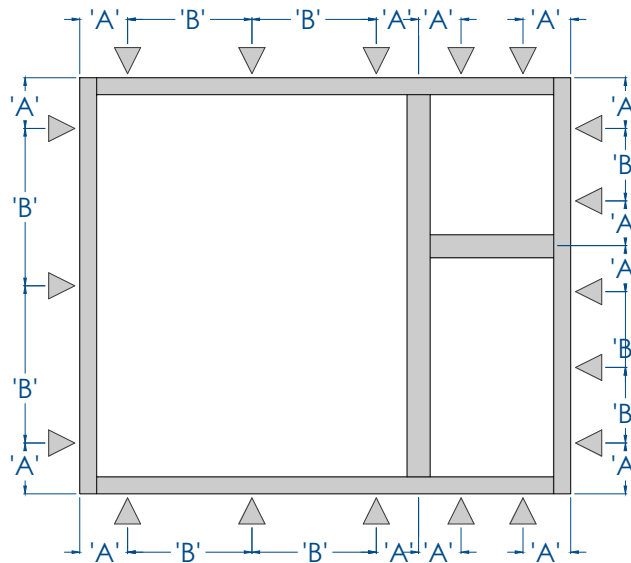

FIG. 3

STEP 4

USING TREMCO's Proglaze ETA SYSTEM

- Building conditions requiring Proglaze ETA membrane may be used around the perimeter of the window.
- Consult TREMCO for Sealing of ETA membrane.



A = max. 3" [76mm]
B = max 18" O.C [457mm]

FIG. 4

STEP 1

- a. Ensure Window Frame is secured and anchored as per approved shop drawings. **See Steps 1-4 on Page 36.**
- b. Ensure Frame Opening is 1/4" [6.5mm] larger than the INSERT VENT frame size. **See FIG 1**
- b. **CRITICAL:** Install two OPEN CELL BAFFLES from both sides at the head of each opening. **See PAGE 27, FIG 1**
- c. Install glazing gasket #1342103, ensure gasket is not wavy. **See FIG 2**
- d. Apply a continuous sealant at the sill filling all 3 cavities. **See FIG 2, item 1**
- e. Seal Anchor Fasteners Heads, **See FIG 2, item 2**
- f. Apply a bed of sealant in all 4 corners from exterior glazing fin to the interior plane of the INSERT VENT. **See FIG 2, item 3**
- g. Apply a dab of sealant to the glazing gasket joint **See FIG 2, item 4**

STEP 2

- a. Push the INSERT VENT into the opening tight to the glazing gasket. **See FIG. 3**
- b. Place 1/8" [3mm] Plastic Horseshoe shims at the sill corners, push the shims until exterior glazing fin. **See FIG. 5**
- c. Center the INSERT VENT and place appropriate horseshoe shims between the vent and the fixed framing. **See FIG. 3**
- d. Drill #10 Pilot holes 1/16" [18mm] from the interior surface through the INSERT VENT and the window frame, 3" [76mm] from inside corner and 18" [457] O.C.
- e. Drill Clearance Holes through the INSERT VENT only.
- f. Install #10 x 2" Long TYPE F fasteners.
- g. If the INSERT VENT is equipped with MPL Tire Bar, #10 x 2" Flat Head TF fasteners must be used in this location. **See FIG. 4**
- h. Remove the clamps and close the sash.

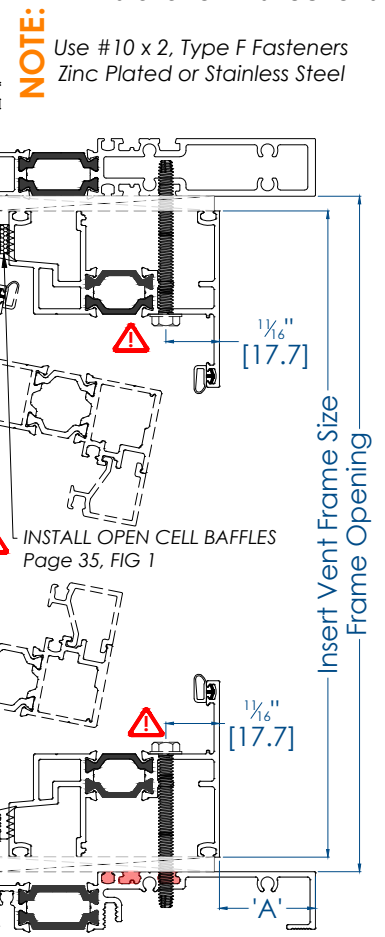

FIG. 1

VENT TYPE	DIM 'A'			
	Dual Glazed		Triple Glazed	
	4 1/4"	5.00"	5"	5 3/4"
1375 PO	1 1/4" [32mm]	1 15/16" [50mm]	1 1/4" [32mm]	1 15/16" [50mm]
1375 PI	1 1/2" [39mm]	2 1/4" [58mm]	1 1/2" [39mm]	2 1/4" [58mm]

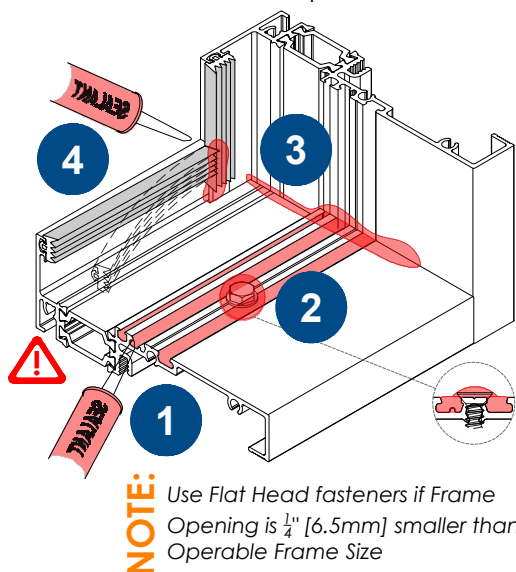

FIG. 2

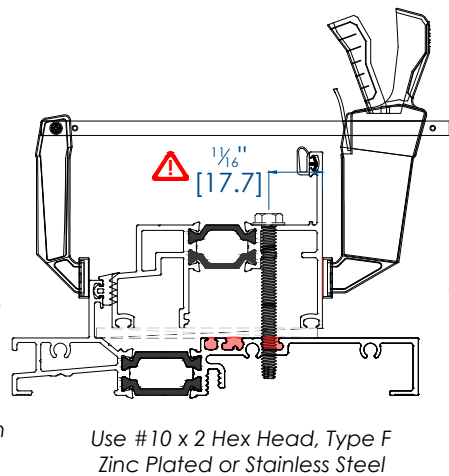

FIG. 3

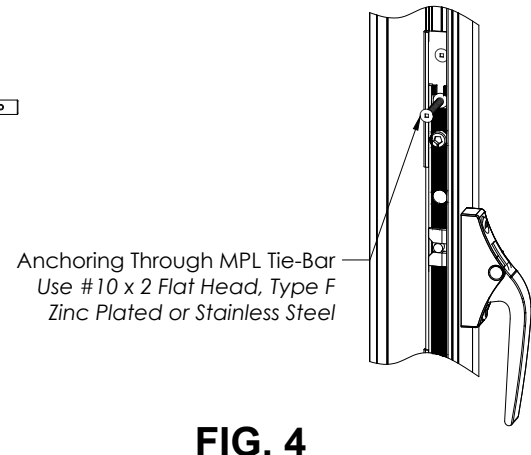

FIG. 4

STEP 3

- a. Cut horseshoe shims flush to interior/exterior frame surface.
- b. Clean perimeter of the frame where seal will be applied using IPA 2 METHOD.
- c. Apply Interior/Exterior seal around the frame and tool.
- d. Seal all the screw heads.

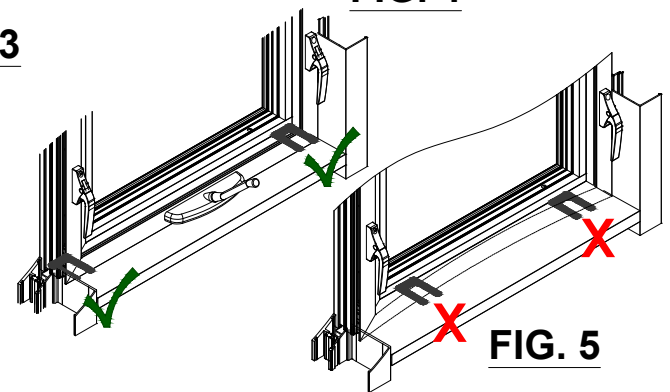

FIG. 5

STEP 1

- Ensure Window Frame is secured and anchored as per approved shop drawings. **See Steps 1-4 on Page 36.**
- CRITICAL:** Install two OPEN CELL BAFFLES from both sides at the head of each opening. **See PAGE 27, FIG 1**
- Install glazing gasket #1342103, ensure gasket is not wavy. **See FIG 2**
- IF ANCHORING THROUGH THE FRAME FLAT HEAD FASTENERS MUST BE USED TO ALLOW THE VENT INSERTION.** **See FIG 1**
- Apply a continuous sealant at the sill filling all 3 cavities. **See FIG 2, item 1**
- Seal Anchor Fasteners Heads, **See FIG 1, item 2**
- Apply a bed of sealant in all 4 corners from exterior glazing fin to the interior plane of the INSERT VENT. **See FIG 2, item 3**
- Apply a dab of sealant to the glazing gasket joint **See FIG 2, item 4**

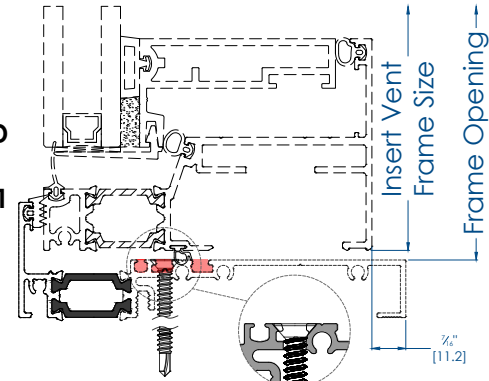

FIG. 1 Flat Head Fastener

STEP 2

- Push the INSERT VENT into the opening tight to the glazing gasket. **See FIG. 3**
- Place $\frac{1}{8}$ " [3mm] Plastic Horseshoe shims at the sill corners, push the shims until outer perimeter bulb gasket. **See FIG. 3**
- Center the INSERT VENT and place appropriate horseshoe shims between the vent and the fixed framing. Adjustable clamps may be used to assist with installation. **See FIG. 3**
- Drill #10 Pilot holes $\frac{1}{16}$ " [18mm] from the interior surface through the INSERT VENT and the window frame, 3" [76mm] from inside corner and 18" [457] O.C.
- Drill Clearance Holes through the INSERT VENT only.
- Install #10 x 2" Long TYPE F fasteners.
- If the INSERT VENT is equipped with MPL Tire Bar, #10 x 2" Flat Head TF fasteners must be used in this location. **See FIG. 4**
- Remove the clamps and close the sash.

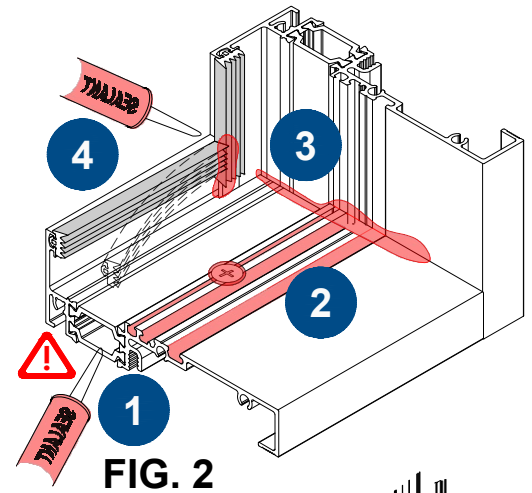

FIG. 2

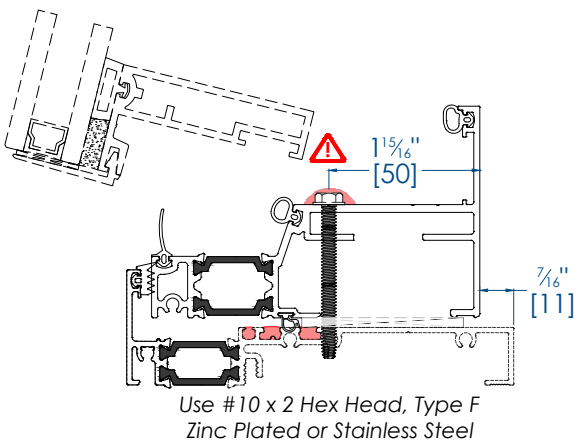

FIG. 3

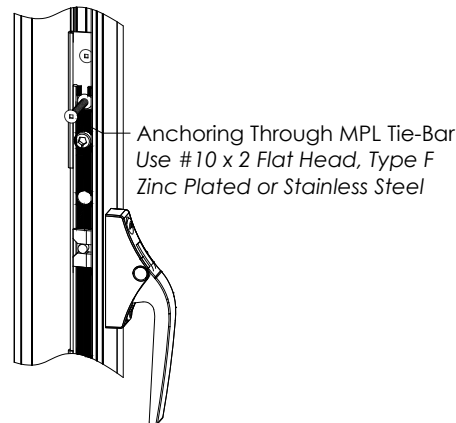

FIG. 4

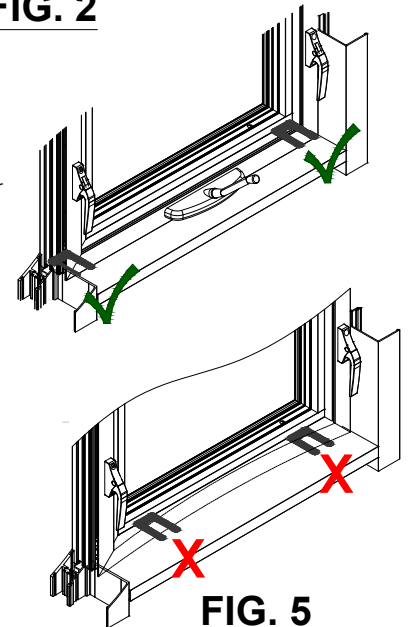

FIG. 5

STEP 3

- Cut horseshoe shims flush to interior/exterior frame surface.
- Clean perimeter of the frame where seal will be applied using IPA 2 METHOD.
- Apply Interior seal around the frame and tool. **See FIG. 6**
- Seal all the screw heads.

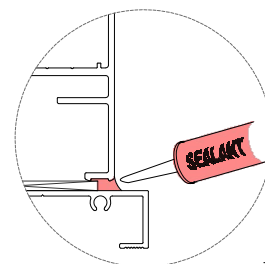
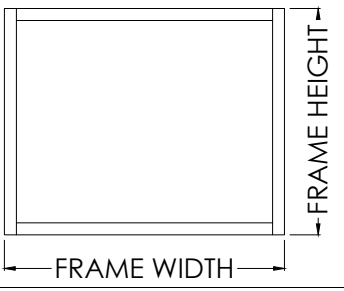
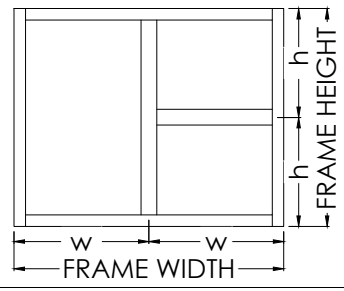
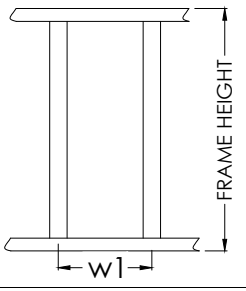

FIG. 6

CALCULATING GLASS SIZES

			
FIXED WINDOW			
GLASS WIDTH	FW - 2" [51mm]	w-1 $\frac{5}{8}$ " [41mm]	w1 - 1 $\frac{1}{4}$ " [32mm]
GLASS HEIGHT	FH - 2" [51mm]	h-1 $\frac{5}{8}$ " [41mm]	FH - 2" [51mm]

STEP 1

- a. **CRITICAL:** Install two OPEN CELL Baffles from both sides at the head of each opening. Use dab of sealant to hold it in place. **See FIG 1.**
- b. Install glazing gasket #1342103, ensure gasket is not wavy. Ensure exterior gasket is not wavy. **See FIG 1.**
- c. Apply a dab of sealant to the glazing gasket joint. **See FIG 1.**

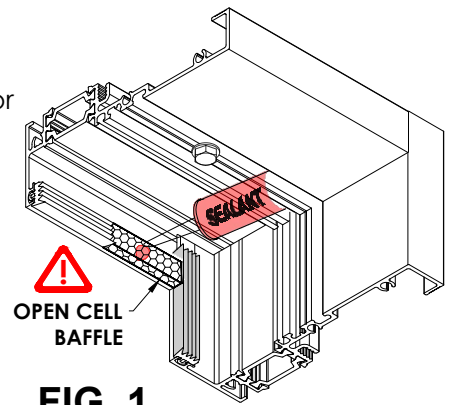

FIG. 1

STEP 2

- a. Place setting blocks at each corner, 6" [150mm] inches from the corner. Dab of sealant can be used to hold it in place. **DO NOT BLOCK WEEP HOLES. See FIG 2.**
- b. Set the glass onto the Setting Blocks and center the glass in the opening. **See FIG. 3**
- c. Temporarily install a small piece of glass stop at the head, to prevent glass from falling out.

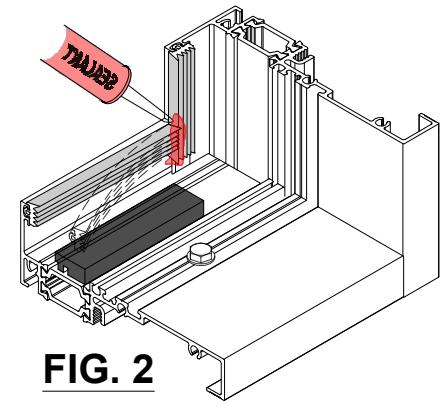

FIG. 2

STEP 3

- a. Cut airseal gasket 1/4" [6] longer per foot to avoid shrinkage at a later stage. **See FIG. 4**
- b. Starting at the sill, insert airseal gasket starting from one end, repeat this every 16 inches. Ensure opposite end of the gasket is inserted before rolling remaining gasket. **See FIG. 5.**

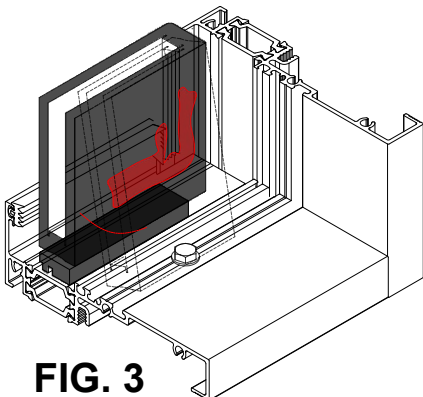

FIG. 3

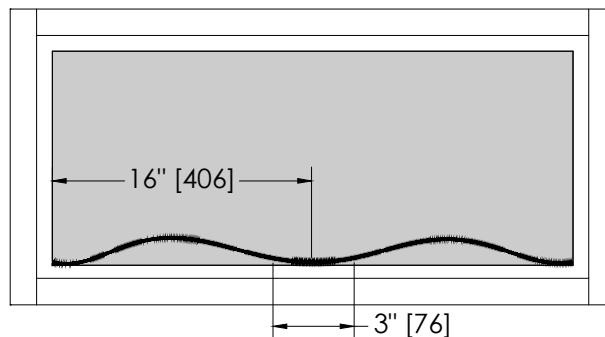

FIG. 4

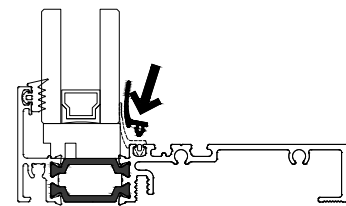

FIG. 5

NEXT PAGE

STEP 4

- a. Repeat step 3 by inserting vertical airseal gasket ensuring it overlaps the gasket at the sill. Finally insert gasket at the head overlapping gaskets at both side. **See FIG. 1**
- b. Clean gasket corners with IPA2 method.
- c. Using a tooling stick peel back overlapping gasket and apply sealant in-between gaskets, and around the corner to prevent air leakage. **See FIG. 2**

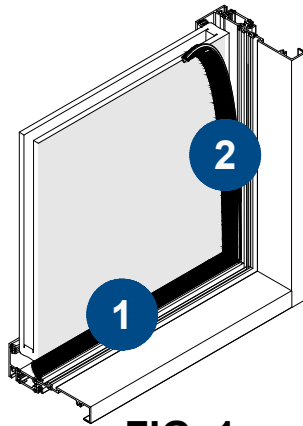

FIG. 1

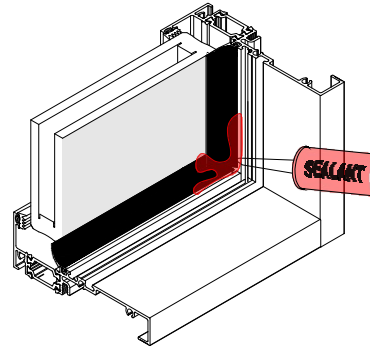

FIG. 2

STEP 5

- a. Reinstall Glass Stops, starting with horizontals first. **See FIG. 3, STEPS 1-2**
- b. Cut glazing gasket 1/4" [6] inch longer per foot to avoid any shrinkage. **See FIG. 4**
- c. Insert glazing gasket starting from one end, repeat this every 16" [406]. Ensure opposite end of the gasket is inserted before rolling remaining gasket. **See FIG. 3, STEPS 3**
- d. Ensure glazing gasket is pressing against airseal gasket. **See FIG. 3, STEPS 4**

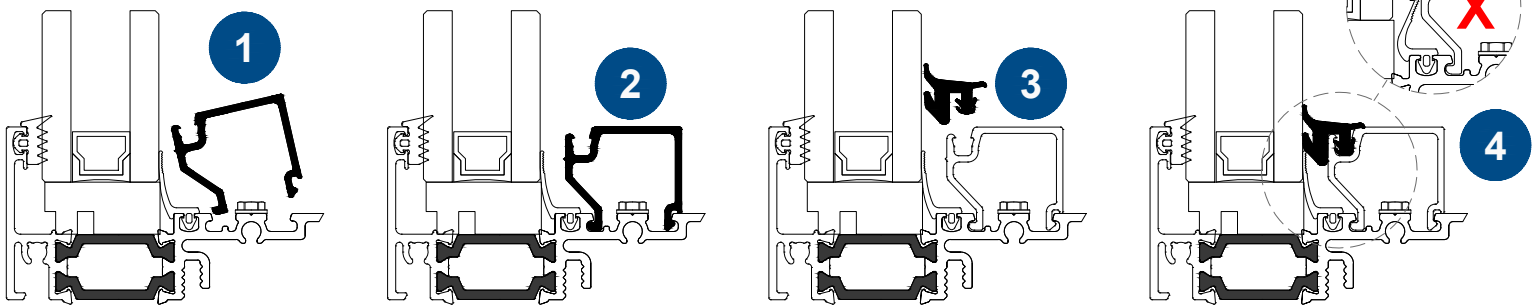

FIG. 3

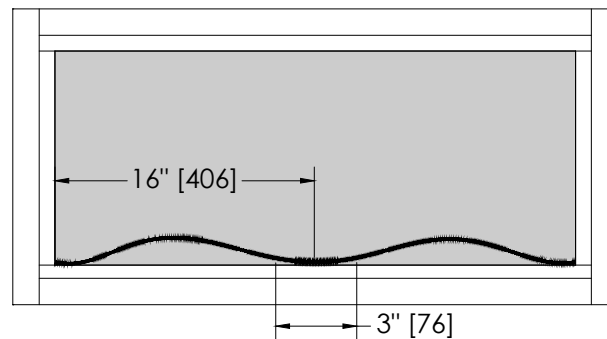

FIG. 4