

RainBlade

2970AW ShadowLine

Interior glazed, full rainscreen design with bull nose profile

Vitrer de l'intérieur avec écran pare pluie et profilé avec un nez

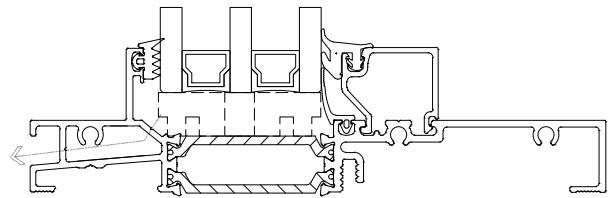
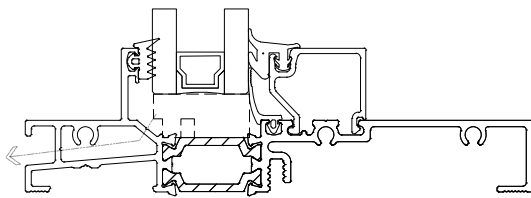

Primary components.....	2-5
<i>Composantes principales</i>	
Thermal Simulation chart.....	5-8
<i>Graphiques de simulation thermique.....</i>	9-12
Typical Details / <i>Détails typiques</i>/.....	13-30

2970AW ShadowLine

Primary Components
Composantes principales

A297201

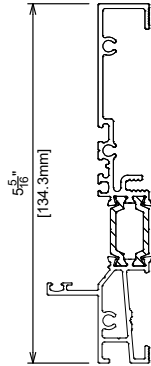

*Sill Frame
Dbl. Glazed*

A297202

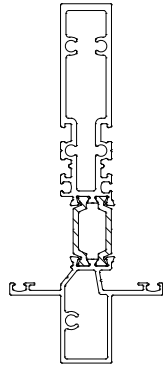

*Intermediate Frame
Dbl. Glazed*

A297203

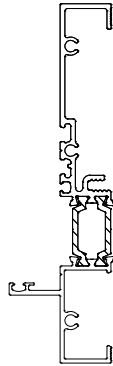

*Perimeter
Frame
Dbl. Glazed*

A297204

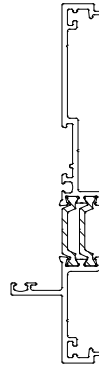

*Split Mullion A
Dbl. Glazed*

A297205

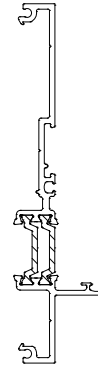

*Split Mullion B
Dbl. Glazed*

A297206

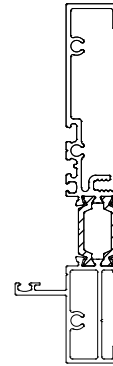

*Perimeter Frame
Closed Nose
Dbl. Glazed*

A297301

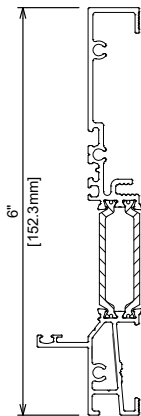

*Sill Frame
Tpl. Glazed*

A297302

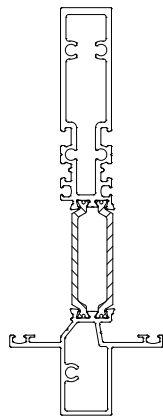

*Intermediate Frame
Tpl. Glazed*

A297303

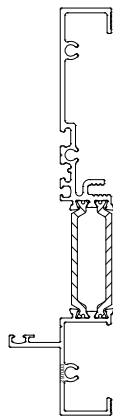

*Perimeter
Frame
Tpl. Glazed*

A297304

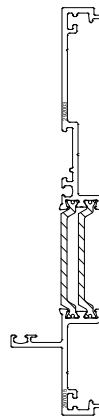

*Split Mullion A
Tpl. Glazed*

A297305

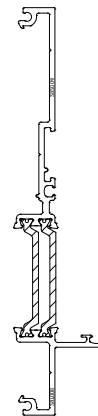

*Split Mullion B
Tpl. Glazed*

A297306

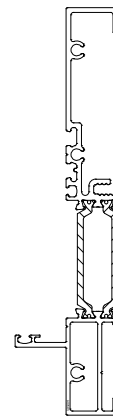

*Perimeter Frame
Closed Nose
Tpl. Glazed*

December 2024

2970AW ShadowLine

Primary Components
Composantes principales

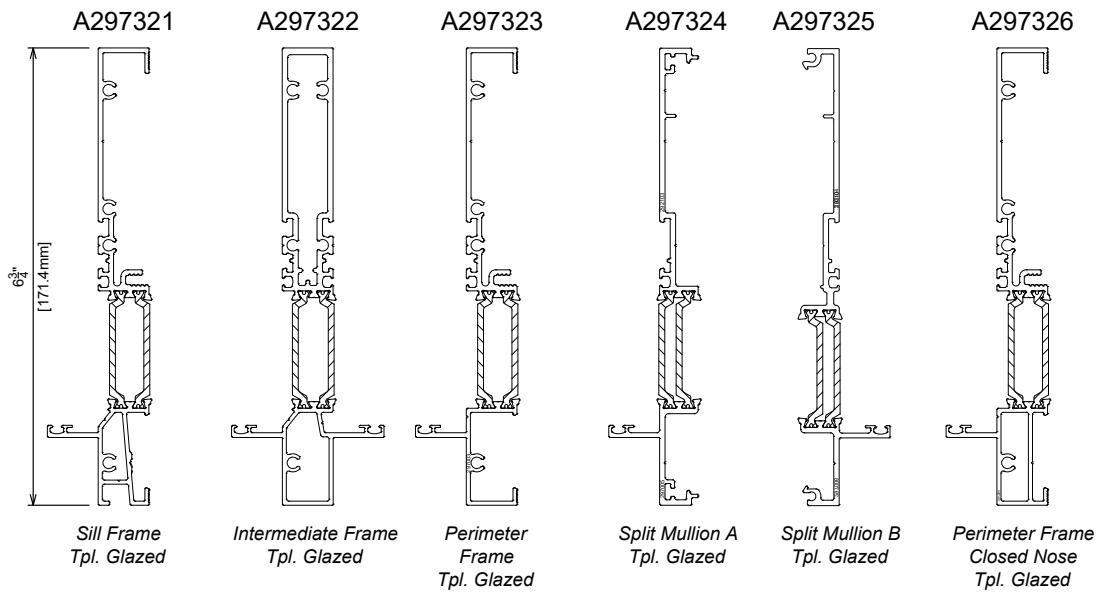
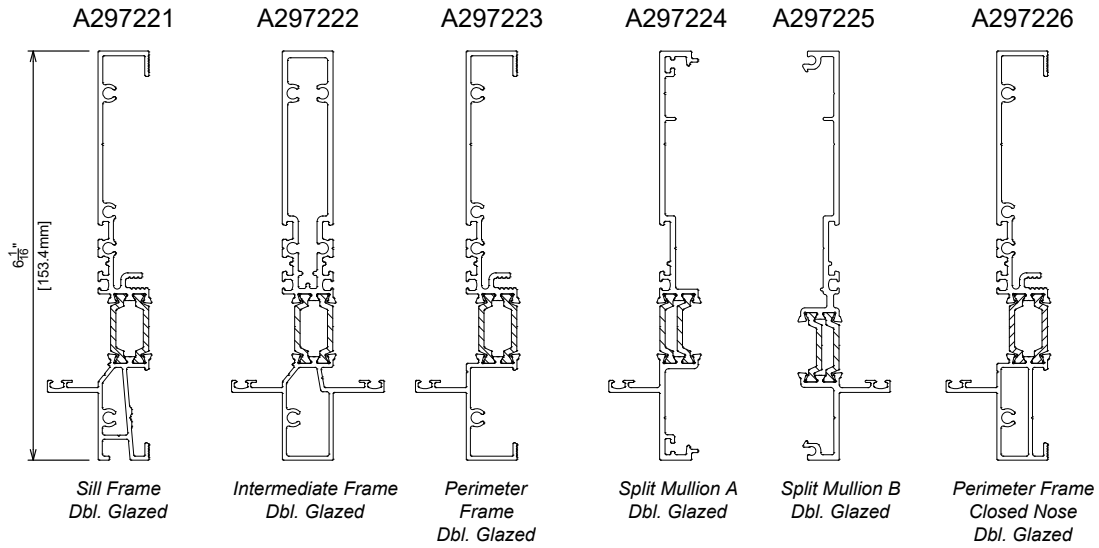

December 2024

2970AW ShadowLine

Primary Components
Composantes principales

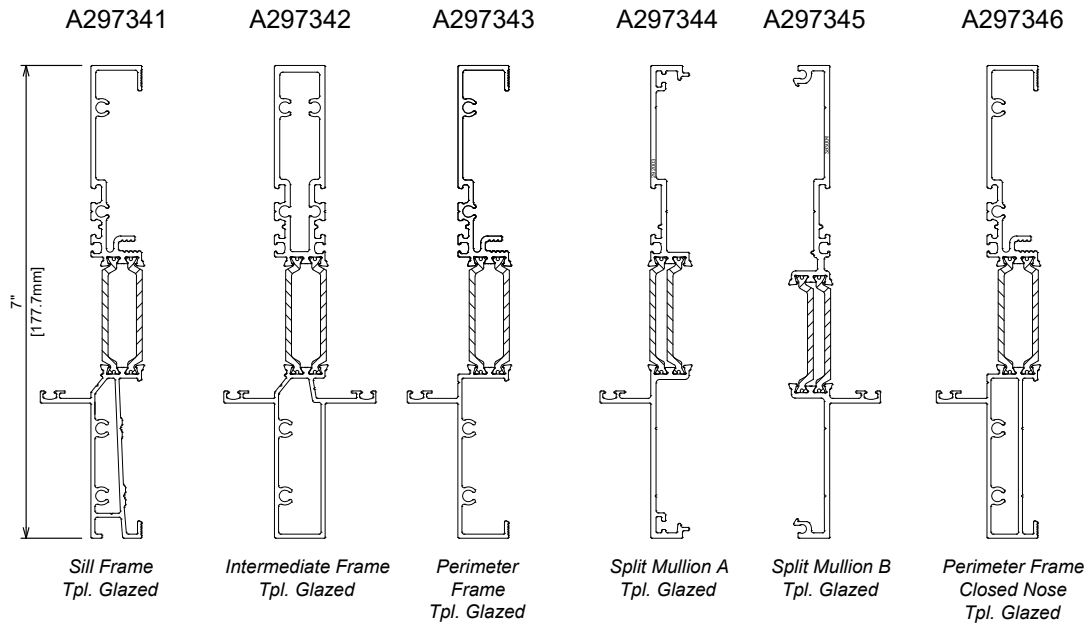
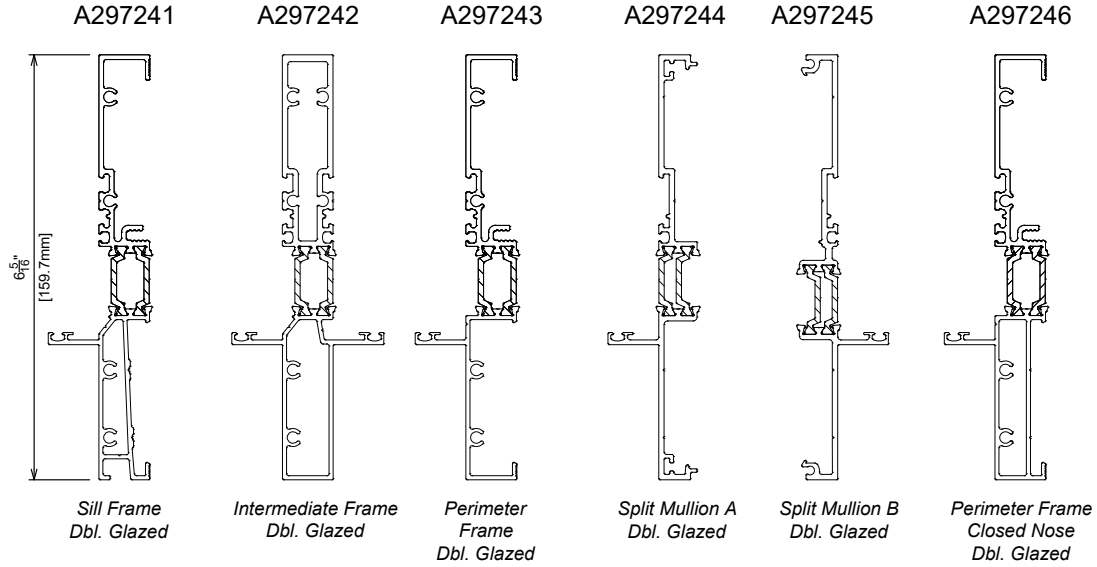

December 2024

2970AW ShadowLine

Primary Components
Composantes principales

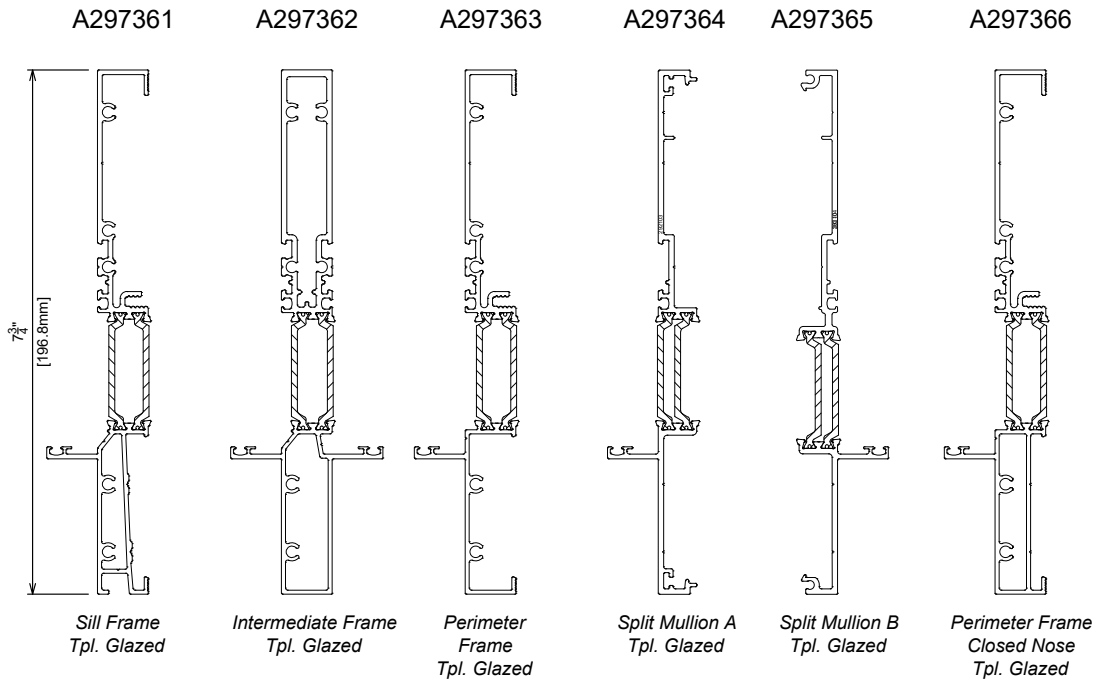
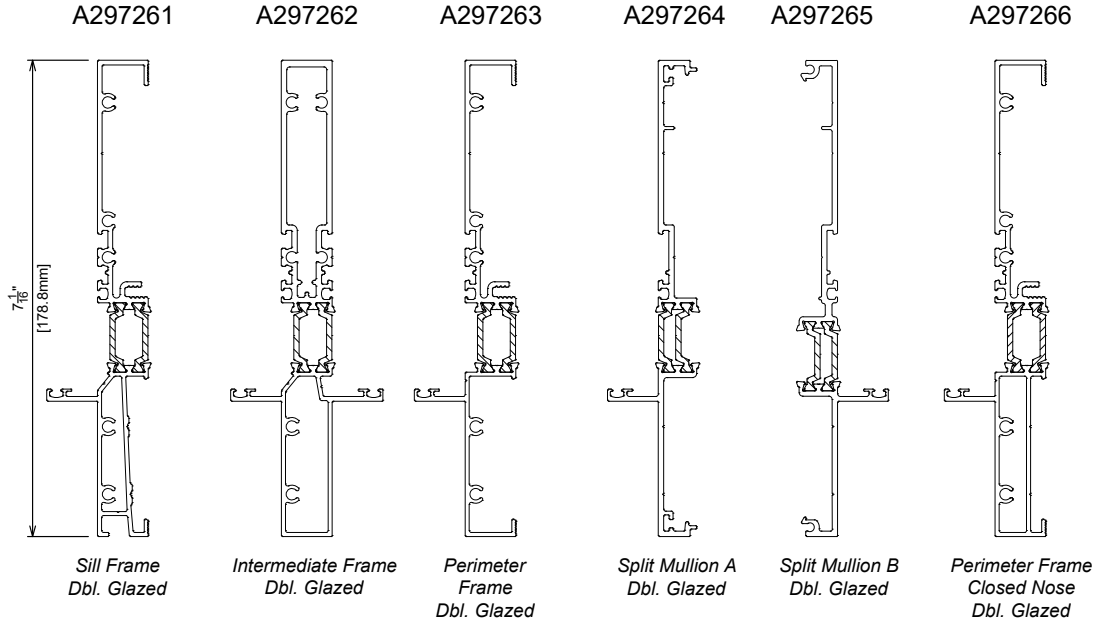

December 2024

THE FOLLOWING THERMAL CHARTS ARE TO BE USED TO DETERMINE OVERALL U VALUE OF THE PRODUCT BY KNOWING U VALUE CENTRE OF GLASS AND SELECTED SPACER OR DETERMINE CENTRE OF GLASS U VALUE AND SPACER BY KNOWING THE PRODUCT REQUIREMENTS FOR U VALUE.

DETERMINE CENTRE OF GLASS U VALUE

- 1) Choose the total system U value from the chart below (vertical axis).
- 2) Based on this point come across horizontally until you reach the specific spacer bar (metallic or non-metallic)
- 3) From this point come down vertically until you reach the horizontal axis and your centre of glass U value

DETERMINE TOTAL SYSTEM U VALUE

- 1) Choose your centre of glass U value from the chart below (horizontal axis).
- 2) Based on this point come up vertically until you reach the specific spacer bar (metallic or non-metallic)
- 3) From this point come across horizontally until you reach the vertical axis and your total system U value

A = Double glazed with Generic Group1

-Spacer containing aluminum

B = Double glazed with Generic Group4

-Spacer containing all non metallic materials

CHART BASED ON 1" (25.4 mm)
DOUBLE GLAZED SEALED UNIT

EXAMPLE:

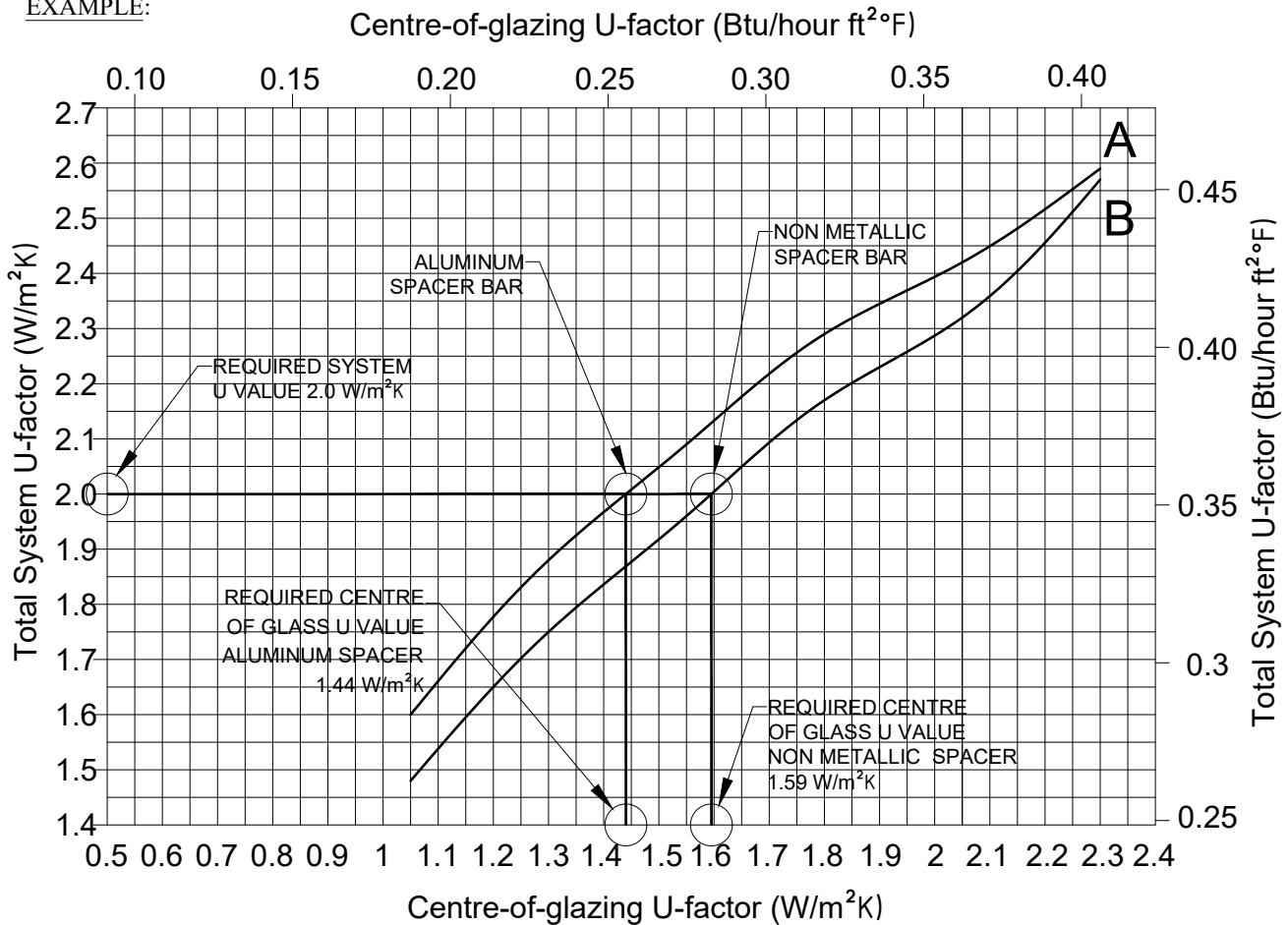

ENVIRONMENTAL CONDITIONS: NFRC 100-2001		
Inside Air Temperature	Outside Air Temperature	Outside Wind Speed
21° C	-18° C	5.5 m/s

December 2024

THE FOLLOWING THERMAL CHARTS ARE TO BE USED TO DETERMINE OVERALL U VALUE OF THE PRODUCT BY KNOWING U VALUE CENTRE OF GLASS AND SELECTED SPACER OR DETERMINE CENTRE OF GLASS U VALUE AND SPACER BY KNOWING THE PRODUCT REQUIREMENTS FOR U VALUE.

- Curves represent independently tested simulation results based on double glazing options using the lowest (curve A) and highest (curve B) performing spacers. Spacer conductance values are based on nfrc 100-2010 section 5.9.5.1.
- Simulation methodology followed nfrc 100-2010
- Simulated window is $47 \frac{1}{4}$ "(1200mm) x $59 \frac{1}{16}$ "(1500mm) as per NFRC 100-2010 table 4.3.
- The charts should be used as a budget or design guide for fenestration product u-factor and rating purposes.

A = Double glazed with Generic Group1
 -Spacer containing aluminum
 B = Double glazed with Generic Group4
 -Spacer containing all non metallic materials

CHART BASED ON 1" (25.4 mm)
 DOUBLE GLAZED SEALED UNIT

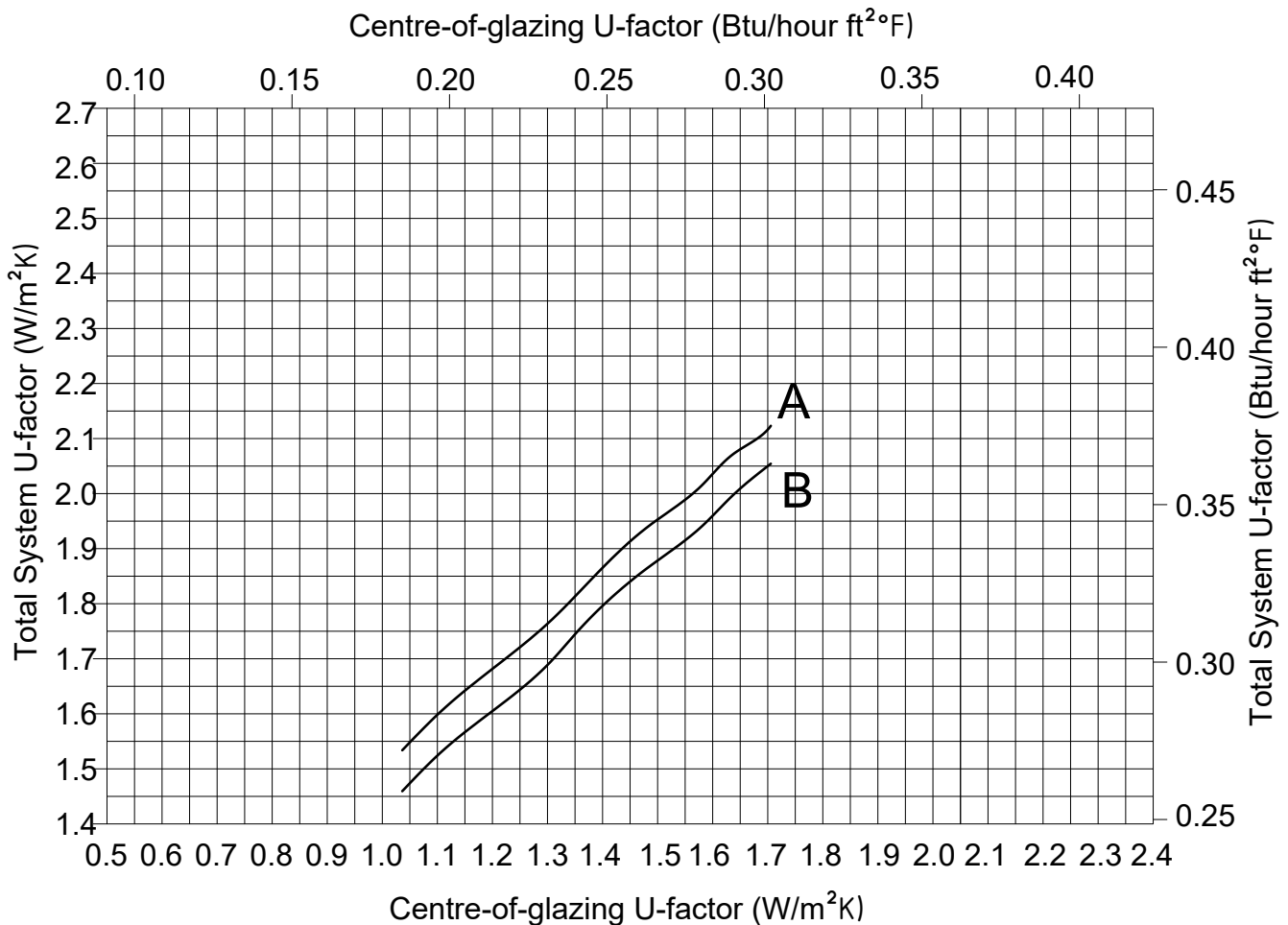

ENVIRONMENTAL CONDITIONS: NFRC 100-2001		
Inside Air Temperature	Outside Air Temperature	Outside Wind Speed
21° C	-18° C	5.5 m/s

December 2024

THE FOLLOWING THERMAL CHARTS ARE TO BE USED TO DETERMINE OVERALL U VALUE OF THE PRODUCT BY KNOWING U VALUE CENTRE OF GLASS AND SELECTED SPACER OR DETERMINE CENTRE OF GLASS U VALUE AND SPACER BY KNOWING THE PRODUCT REQUIREMENTS FOR U VALUE.

- Curves represent independently tested simulation results based on triple glazing options using the lowest (curve A) and highest (curve B) performing spacers. Spacer conductance values are based on nfrc 100-2010 section 5.9.5.1.
- Simulation methodology followed nfrc 100-2010
- Simulated window is $47 \frac{1}{4}$ "(1200mm) x $59 \frac{1}{16}$ "(1500mm) as per NFRC 100-2010 table 4.3.
- The charts should be used as a budget or design guide for fenestration product u-factor and rating purposes.

A = Triple glazed with Generic Group1
 -Spacer containing aluminum
 B = Triple glazed with Generic Group4
 -Spacer containing all non metallic materials

CHART BASED ON $1 \frac{11}{16}$ " (43 mm)
 TRIPLE GLAZED SEALED UNIT

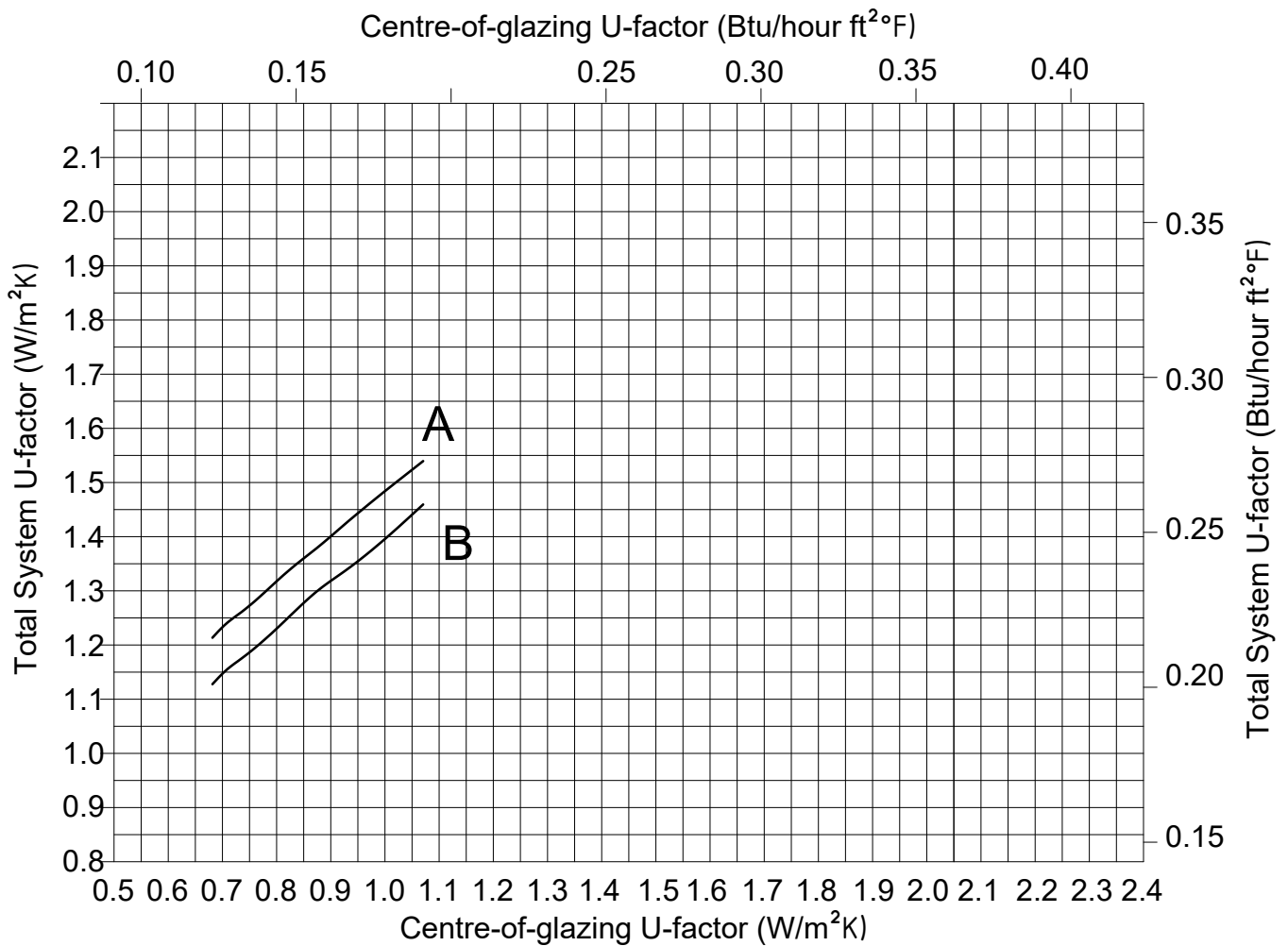

ENVIRONMENTAL CONDITIONS: NFRC 100-2001		
Inside Air Temperature	Outside Air Temperature	Outside Wind Speed
21° C	-18° C	5.5 m/s

December 2024

LES GRAPHIQUES DE SIMULATION THERMIQUE SUIVANTS DOIVENT ÊTRE UTILISÉS POUR DÉTERMINER LA VALEUR U TOTALE DU PRODUIT EN CONNAISSANT LA VALEUR U AU CENTRE DU VERRE AINSI QUE LE TYPE D'INTERCALAIRE CHOISI, OU POUR DÉTERMINER LA VALEUR U DU CENTRE DE LA VITRE ET LE TYPE D'INTERCALAIRE EN CONNAISSANT LA VALEUR U EXIGÉE DU PRODUIT.

DÉTERMINER LA VALEUR U DU CENTRE DE LA VITRE

- 1) Choisir la valeur U totale dans le graphique ci-dessous (axe vertical).
- 2) En se basant sur ce point, se déplacer à l'horizontale jusqu'à l'intercalaire spécifique (métallique ou non-métallique).
- 3) À partir de ce point, passer à la verticale jusqu'à l'axe horizontal et votre valeur U au centre de la vitre.

DÉTERMINER LA VALEUR U TOTALE DU SYSTÈME

- 1) Choisir la valeur U au centre du verre dans le graphique ci-dessous (axe horizontal).
- 2) En se basant sur ce point, se déplacer verticalement vers le haut jusqu'à l'intercalaire spécifique (métallique ou non-métallique).
- 3) À partir de ce point, passer à l'horizontale jusqu'à l'axe vertical et votre valeur U totale du système.

A = Double vitrage avec groupe générique 1

- intercalaire contenant de l'aluminium

B = Double vitrage avec groupe générique 4

- intercalaire sans matériaux métalliques

GRAPHIQUE BASÉ SUR UN DOUBLE VITRAGE SCELLÉ DE 1" (25,4 mm)

EXEMPLE :

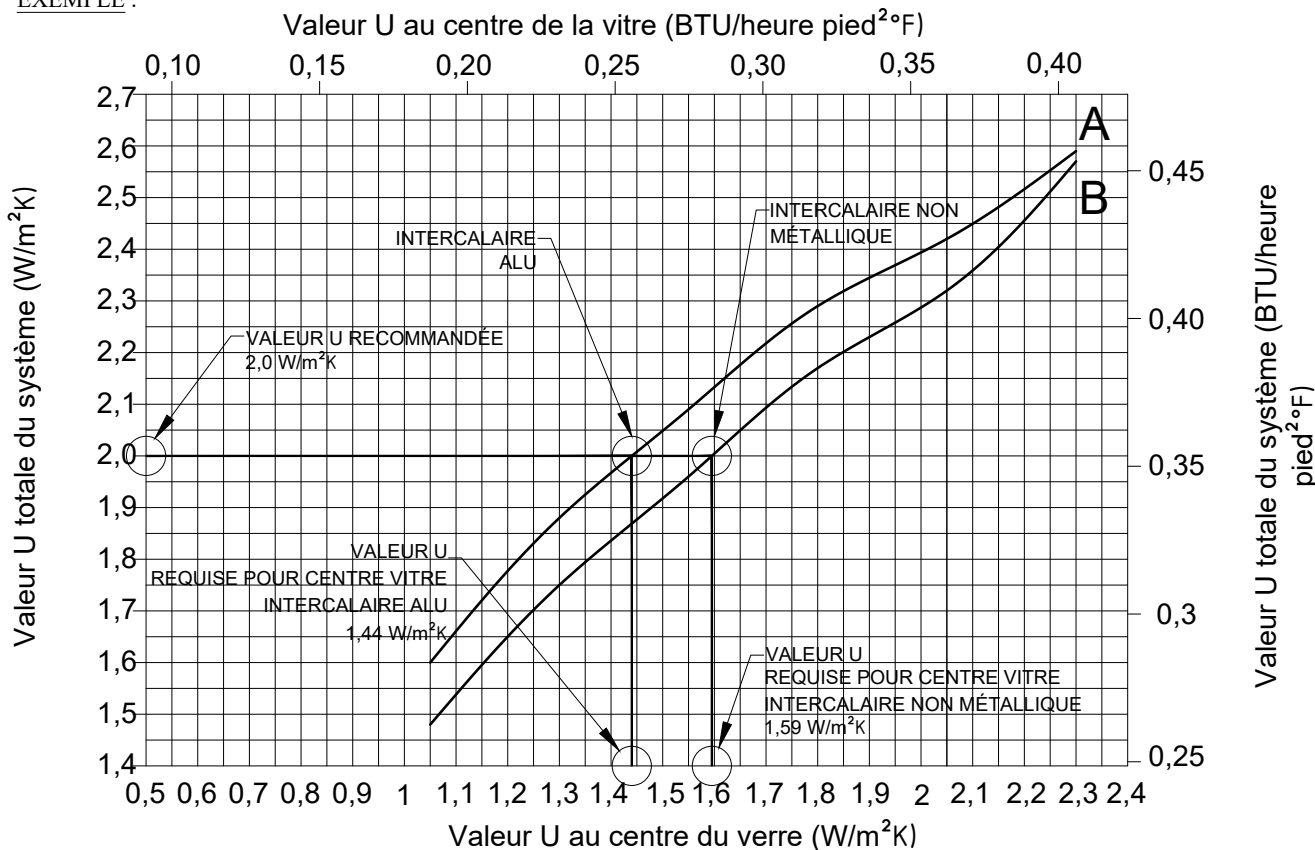

CONDITIONS AMBIANTES : NFRC 100-2001		
Temp. de l'air intérieur	Temp. de l'air extérieur	Vitesse du vent extérieur
21° C	-18° C	5.5 m/s

FOR ENGLISH VERSION PLEASE SEE PAGE: 2.4.2.1

LES GRAPHIQUES DE SIMULATION THERMIQUE SUIVANTS DOIVENT ÊTRE UTILISÉS POUR DÉTERMINER LA VALEUR U TOTALE DU PRODUIT EN CONNAISSANT LA VALEUR U AU CENTRE DU VERRE AINSI QUE LE TYPE D'INTERCALAIRE CHOISI, OU POUR DÉTERMINER LA VALEUR U DU CENTRE DE LA VITRE ET LE TYPE D'INTERCALAIRE EN CONNAISSANT LA VALEUR U EXIGÉE DU PRODUIT.

DÉTERMINER LA VALEUR U DU CENTRE DE LA VITRE

- 1) Choisir la valeur U totale dans le graphique ci-dessous (axe vertical).
- 2) En se basant sur ce point, se déplacer à l'horizontale jusqu'à l'intercalaire spécifique (métallique ou non-métallique).
- 3) À partir de ce point, passer à la verticale jusqu'à l'axe horizontal et votre valeur U au centre de la vitre.

DÉTERMINER LA VALEUR U TOTALE DU SYSTÈME

- 1) Choisir la valeur U au centre du verre dans le graphique ci-dessous (axe horizontal).
- 2) En se basant sur ce point, se déplacer verticalement vers le haut jusqu'à l'intercalaire spécifique (métallique ou non-métallique).
- 3) À partir de ce point, passer à l'horizontale jusqu'à l'axe vertical et votre valeur U totale du système.

- A = Double vitrage avec groupe générique 1
- intercalaire contenant de l'aluminium
- B = Double vitrage avec groupe générique 4
- intercalaire sans matériaux métalliques

GRAPHIQUE BASÉ SUR UN DOUBLE VITRAGE SCÉLLÉ DE 1" (25,4 mm)

EXEMPLE :

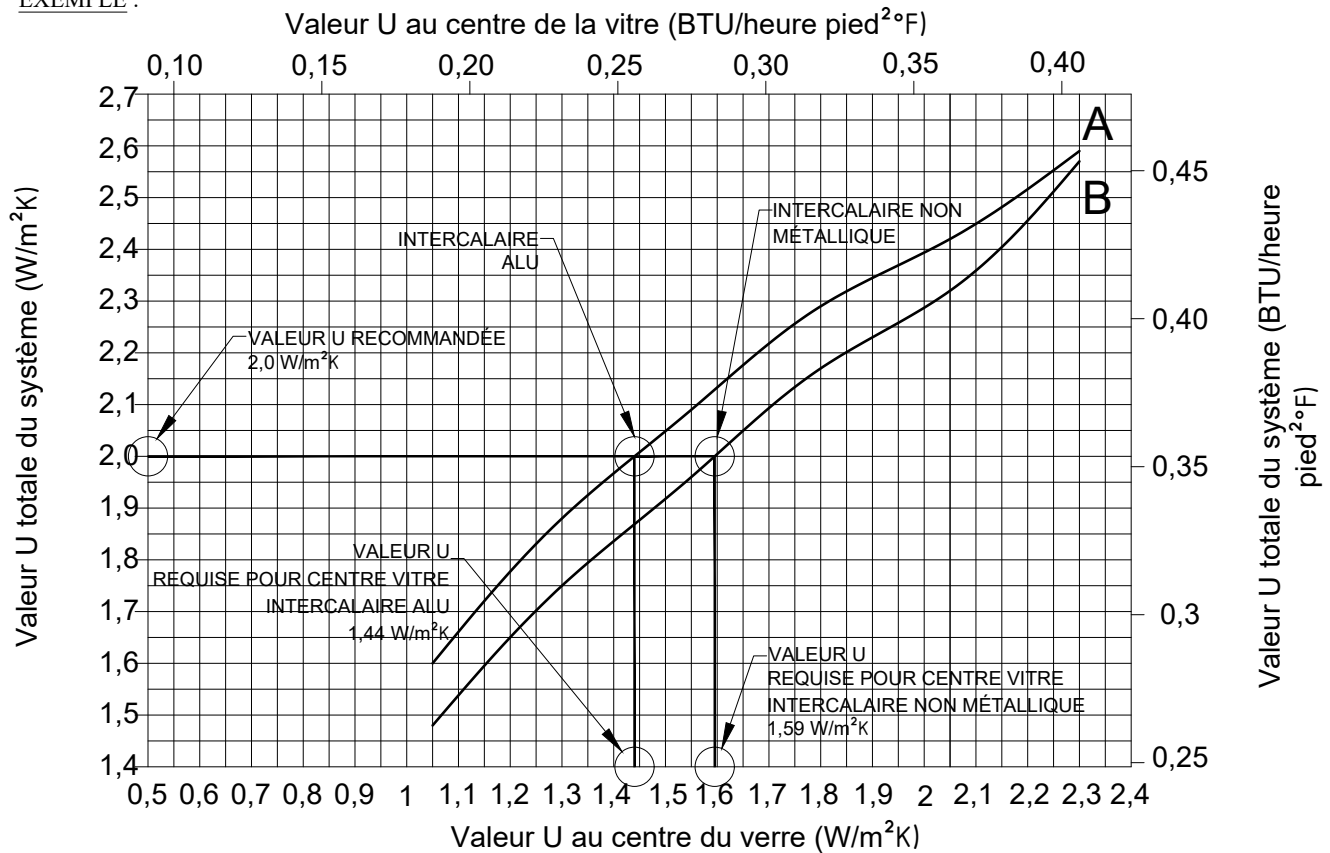

CONDITIONS AMBIANTES : NFRC 100-2001

Temp. de l'air intérieur	Temp. de l'air extérieur	Vitesse du vent extérieur
21° C	-18° C	5.5 m/s

FOR ENGLISH VERSION PLEASE SEE PAGE: 2.4.2.1

December 2024

LES GRAPHIQUES DE SIMULATION THERMIQUE SUIVANTS DOIVENT ÊTRE UTILISÉS POUR DÉTERMINER LA VALEUR U TOTALE DU PRODUIT EN CONNAISSANT LA VALEUR U AU CENTRE DU VERRE AINSI QUE LE TYPE D'INTERCALAIRE CHOISI, OU POUR DÉTERMINER LA VALEUR U DU CENTRE DU VERRE ET LE TYPE D'INTERCALAIRE EN CONNAISSANT LA VALEUR U EXIGÉE DU PRODUIT.

- Les courbes représentent les résultats de simulations effectuées par des laboratoires indépendants en fonction des options de double vitrage utilisant les intercalaires les moins performants (courbe a) et les intercalaires les plus performants (courbe b). Les valeurs de conductance thermique des intercalaires sont fondées sur la norme nfrc 100-2010, section 5.9.5.1.
- La méthodologie employée pour la simulation était conforme à la norme nfrc 100-2010.
- La fenêtre employée pour la simulation mesurait $47 \frac{1}{4}$ "(1200mm) x $59 \frac{1}{16}$ "(1500mm) conformément à la norme nfrc 100-2010, tableau 4.3.
- Les graphiques doivent être utilisés comme guide pour l'établissement du budget ou pour la conception architecturale, pour déterminer la valeur u du produit de vitrage et afin d' établir les caractéristiques nominales.

- A = Double vitrage avec groupe générique 1
- intercalaire contenant de l'aluminium
- B = Double vitrage avec groupe générique 4
- intercalaire sans matériaux métalliques

GRAPHIQUE BASÉ SUR UN DOUBLE VITRAGE SCELLÉ DE 1" (25,4 mm)

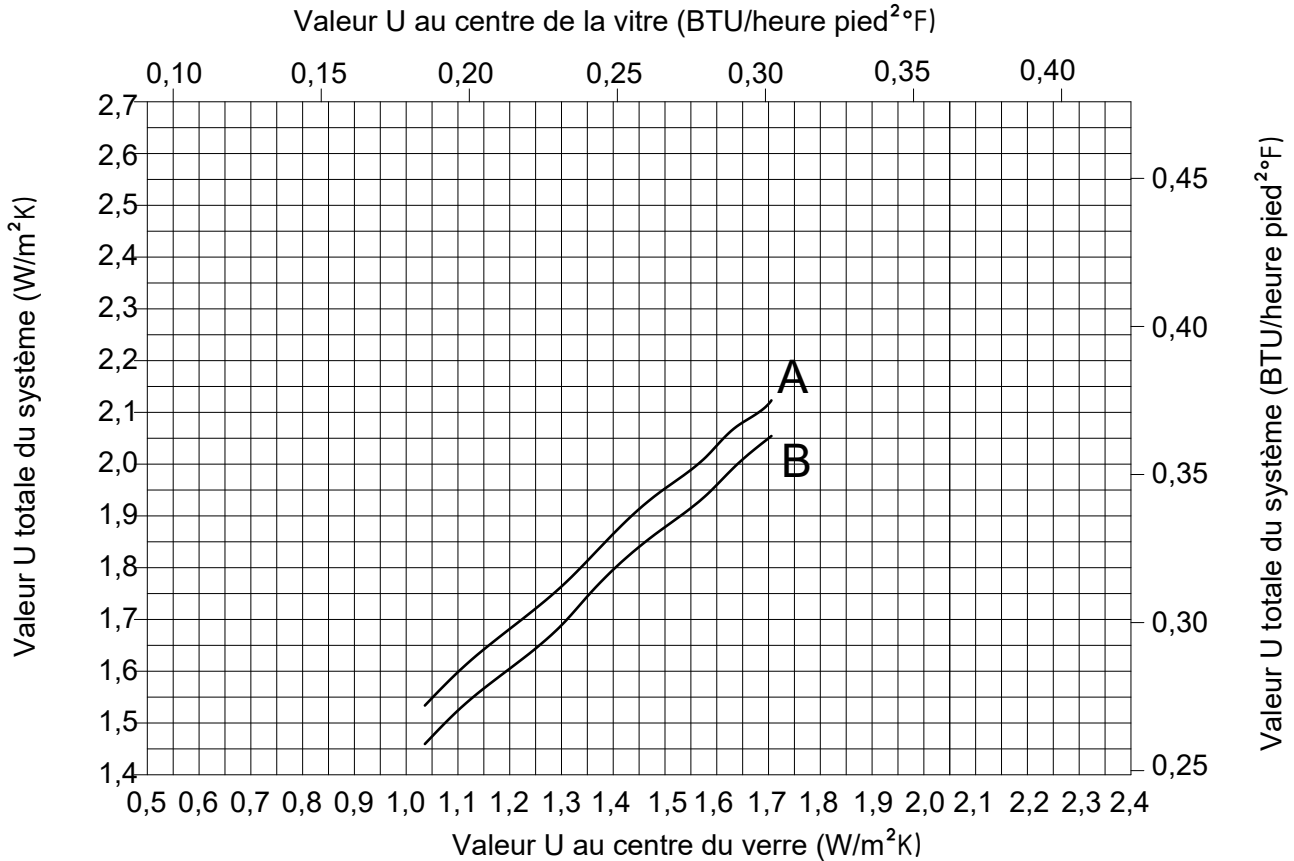

CONDITIONS AMBIANTES : NFRC 100-2001		
Temp. de l'air intérieur	Temp. de l'air extérieur	Vitesse du vent extérieur
21° C	-18° C	5,5 m/s

FOR ENGLISH VERSION PLEASE SEE PAGE: 2.4.2.2

LES GRAPHIQUES DE SIMULATION THERMIQUE SUIVANTS DOIVENT ÊTRE UTILISÉS POUR DÉTERMINER LA VALEUR U TOTALE DU PRODUIT EN CONNAISSANT LA VALEUR U AU CENTRE DU VERRE AINSI QUE LE TYPE D'INTERCALAIRE CHOISI, OU POUR DÉTERMINER LA VALEUR U DU CENTRE DU VERRE ET LE TYPE D'INTERCALAIRE EN CONNAISSANT LA VALEUR U EXIGÉE DU PRODUIT.

- Les courbes représentent les résultats de simulations effectuées par des laboratoires indépendants en fonction des options de triple vitrage utilisant les intercalaires les moins performants (courbe a) et les intercalaires les plus performants (courbe b). Les valeurs de conductance thermique des intercalaires sont fondées sur la norme nrc 100-2010, section 5.9.5.1.
- La méthodologie employée pour la simulation était conforme à la norme nrc 100-2010.
- La fenêtre employée pour la simulation mesurait $47 \frac{1}{4}$ " (1200mm) x $59 \frac{1}{16}$ " (1500mm) conformément à la norme nrc 100-2010, tableau 4.3.
- Les graphiques doivent être utilisés comme guide pour l'établissement du budget ou pour la conception architecturale, pour déterminer la valeur u du produit de vitrage et afin d'établir les caractéristiques nominales.

A = Triple vitrage avec groupe générique 1
 - intercalaire contenant de l'aluminium
 B = Triple vitrage avec groupe générique 4
 - intercalaire sans matériaux métalliques

GRAPHIQUE BASÉ SUR UN TRIPLE
 VITRAGE SCELLE DE $1 \frac{11}{16}$ " (43 mm)

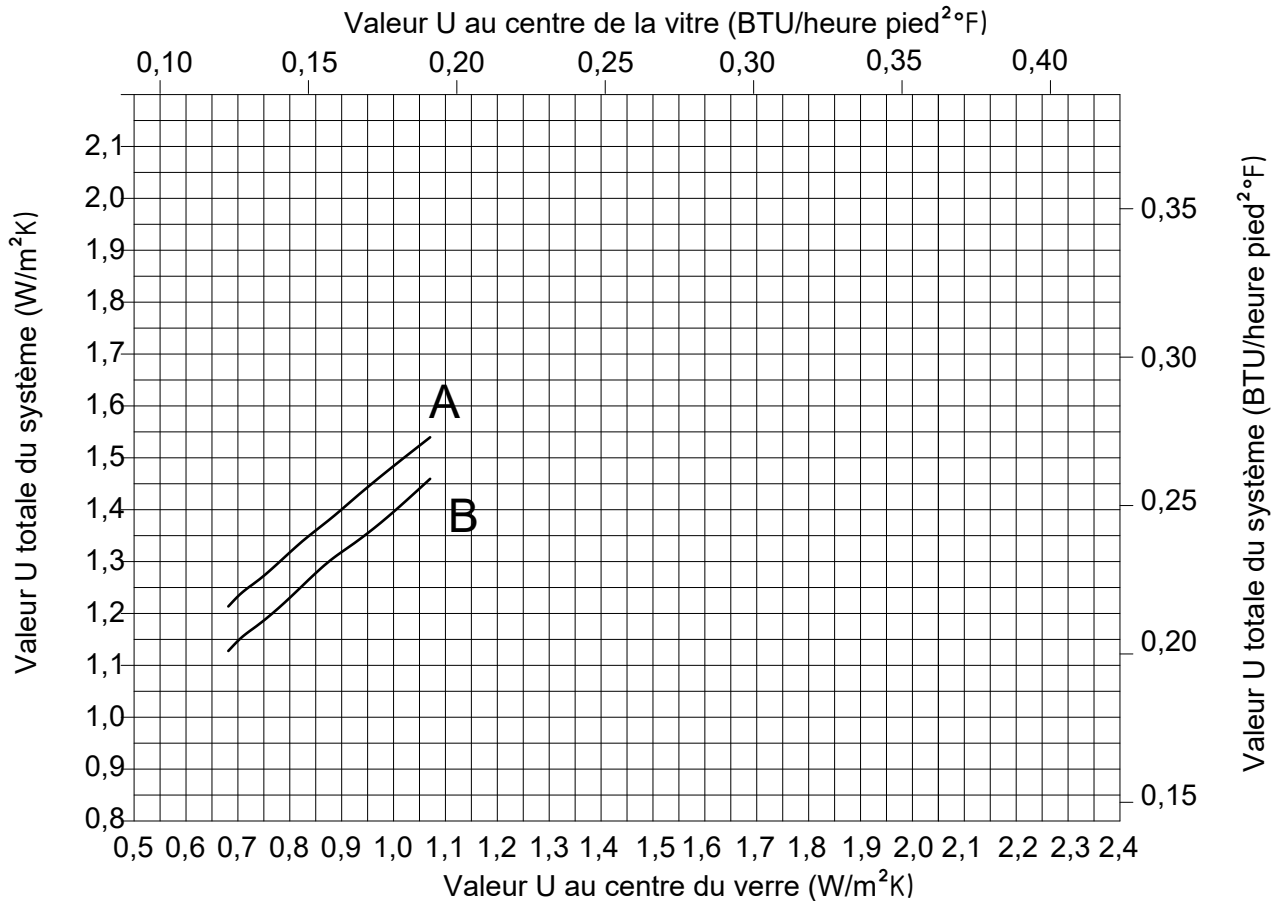

CONDITIONS AMBIANTES : NFRC 100-2001		
Temp. de l'air intérieur	Temp. de l'air extérieur	Vitesse du vent extérieur
21° C	-18° C	5,5 m/s

FOR ENGLISH VERSION PLEASE SEE PAGE: 2.4.2.3

2970AW ShadowLine

Typical details - double glazed
 Détails typiques - double vitrage

6.00" Deep

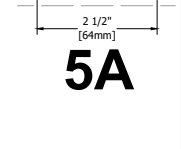
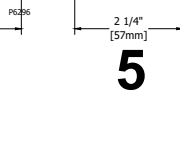
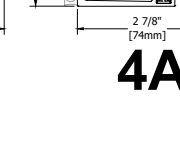
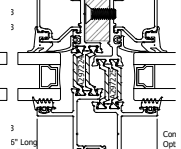
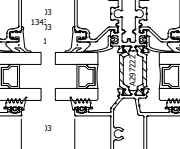
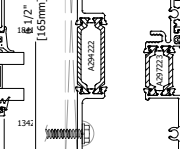
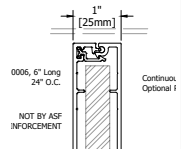
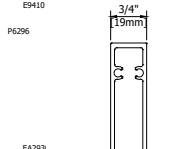
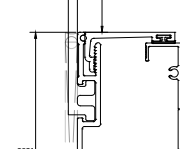
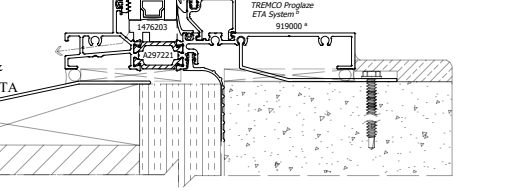
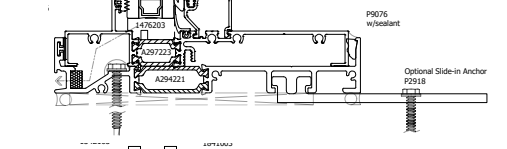
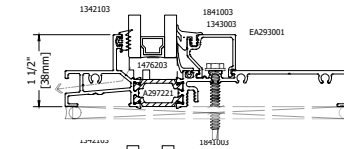
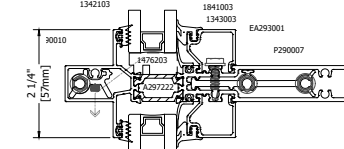
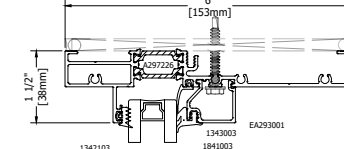
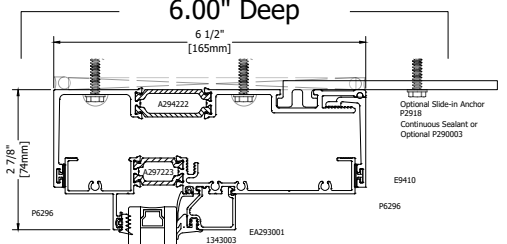
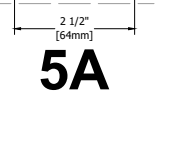
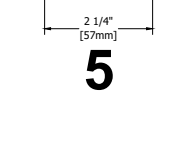
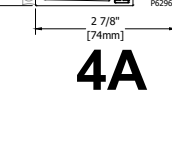
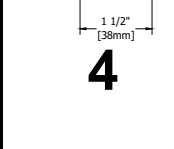
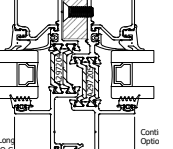
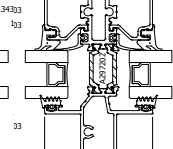
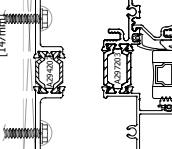
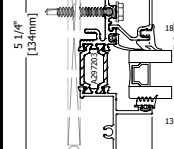
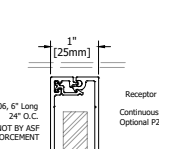
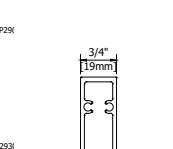
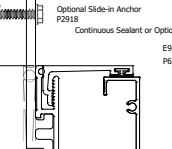
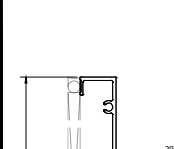
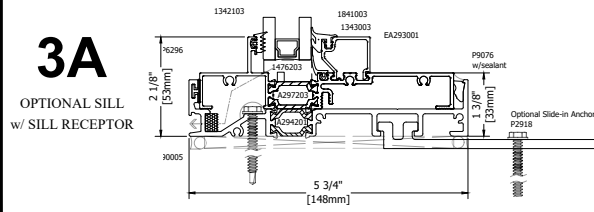
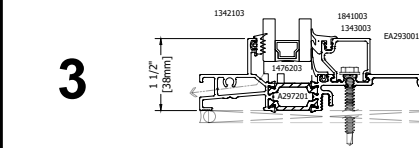
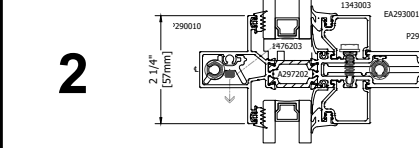
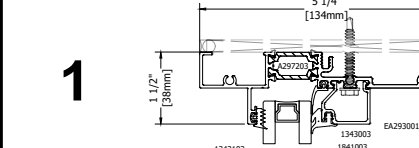
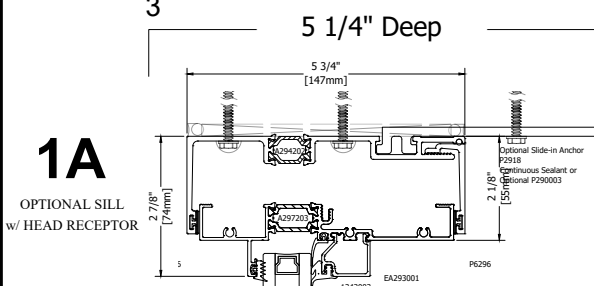
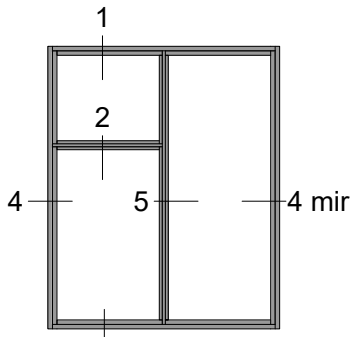

December 2024

For specific product applications, contact your representative.

www.alumicor.com

PAGE 13

www.tubeliteUSA.com



2970AW ShadowLine

Typical details - double glazed
Détails typiques - double vitrage

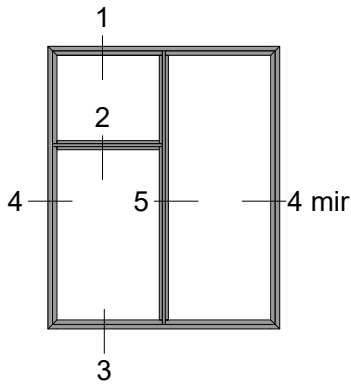

5 1/4" Deep

6.00" Deep

1
MITERED FRAME ASSEMBLY
∠ 45°

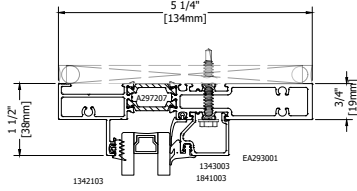

1
MITERED FRAME ASSEMBLY
∠ 45°

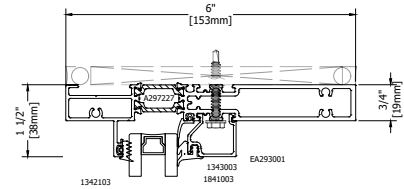

2

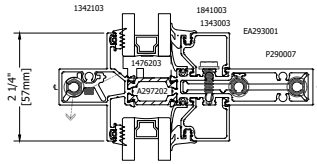

2

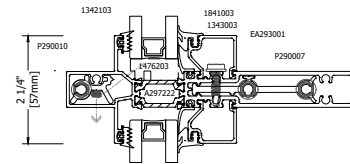

3

MITERED FRAME ASSEMBLY
∠ 45°

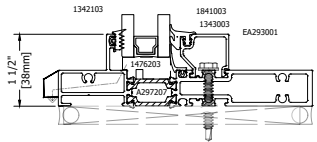

3

MITERED FRAME ASSEMBLY
∠ 45°

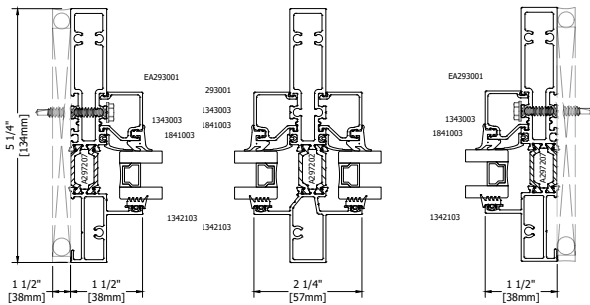
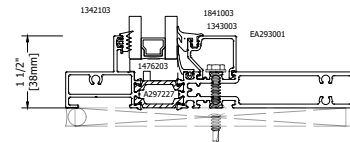

4

MITERED FRAME ASSEMBLY
∠ 45°

5

6

MITERED FRAME ASSEMBLY
∠ 45°

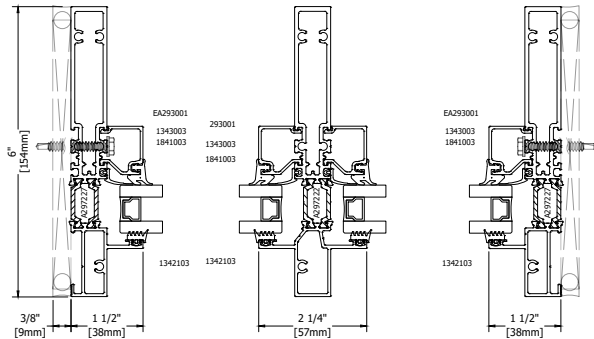

4

MITERED FRAME ASSEMBLY
∠ 45°

5

6

MITERED FRAME ASSEMBLY
∠ 45°

December 2024

2970AW ShadowLine

Typical details with 1375- double glazed
 Détails typiques avec 1375 - double vitrage

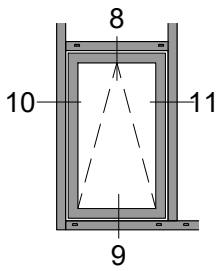

5 1/4" Deep
 w/ 1375 PO Awning

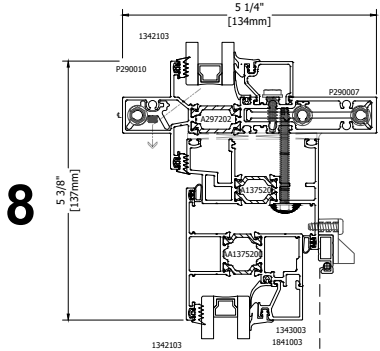

8

6.00" Deep
 w/ 1375 PI HOPPER

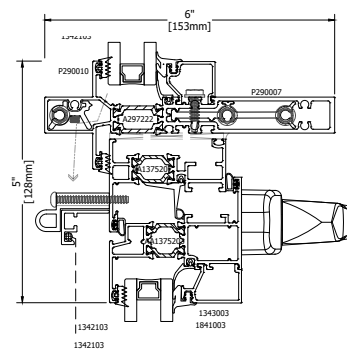

8A

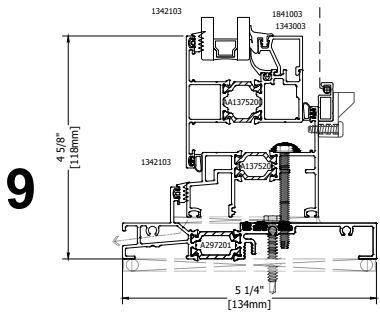

9

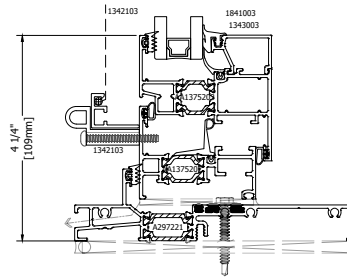

9A

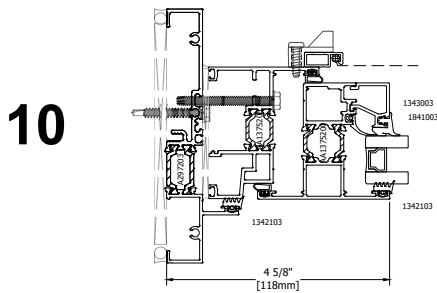

10

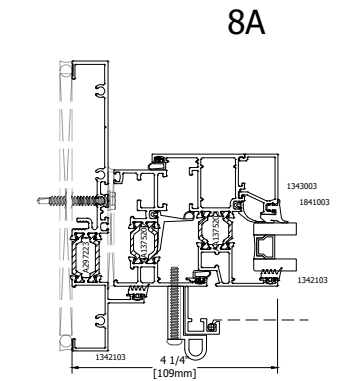

8A

10A

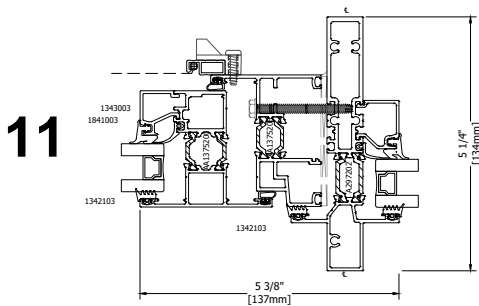

11

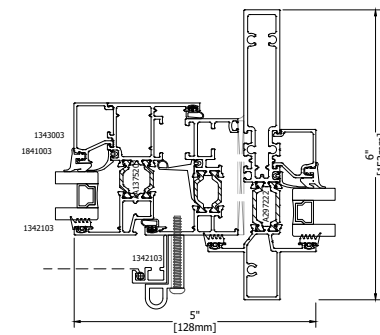

11A

December 2024

Typical details with 1375- double glazed
 Détails typiques avec 1375 - double vitrage

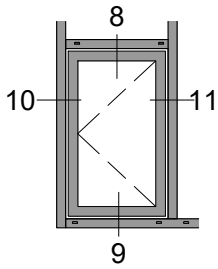

**5 1/4" Deep
 w/ 1375 1375 PO Casement**

8

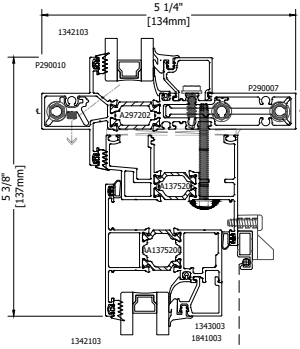

**6.00" Deep
 w/ 1375 PI Casement**

8A

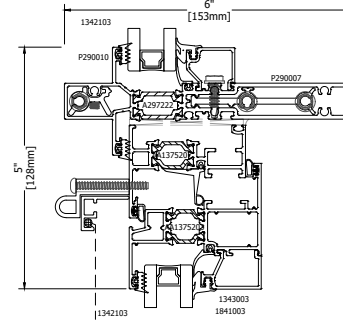

9

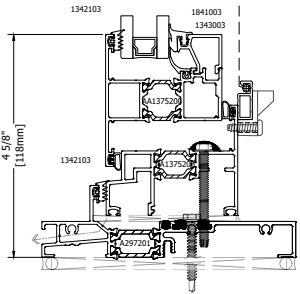

9A

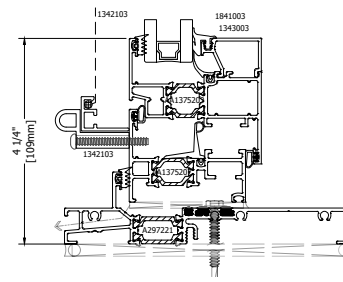

10

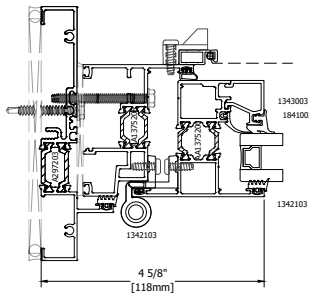

10A

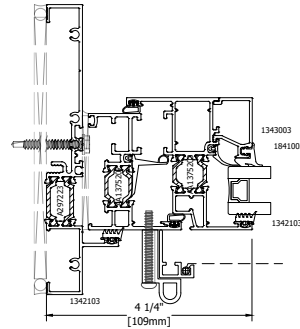

11

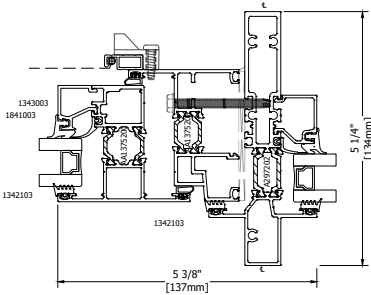

11A

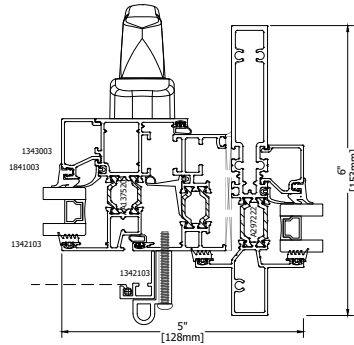

December 2024

Typical details with 5000 Phantom Vent- double glazed
 Détails typiques avec 5000 Phantom Vent- double vitrage

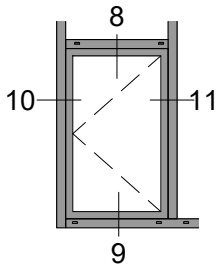

6.00" Deep
 w/ 5000 Phantom Vent
 Casement with "EURO" MPL Handle

8B

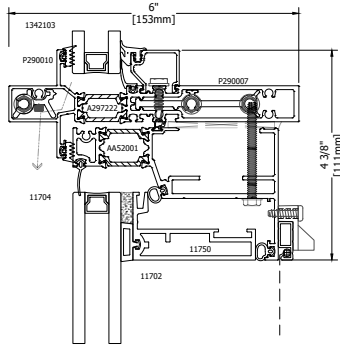

9B

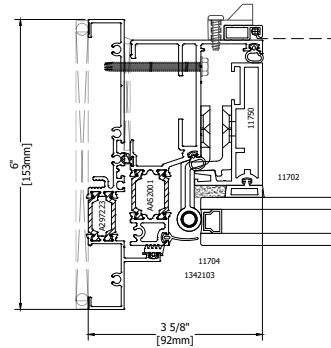
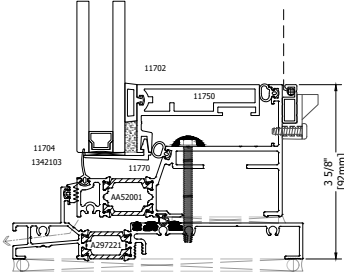

10B

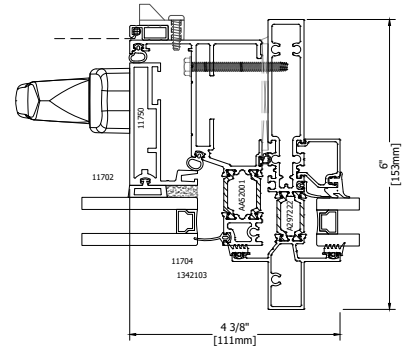

11B

6.00" Deep
 w/ 5000 Phantom Vent
 Casement ROTO & MPL Handle

8C

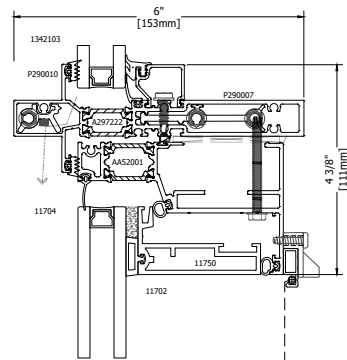

9C

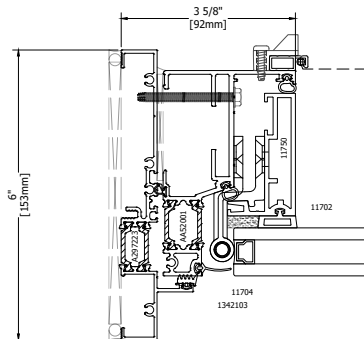
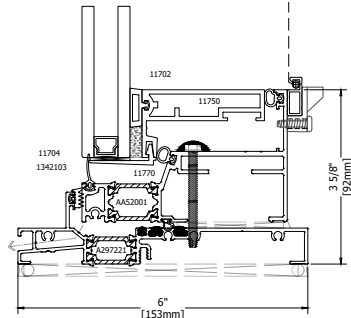

10C

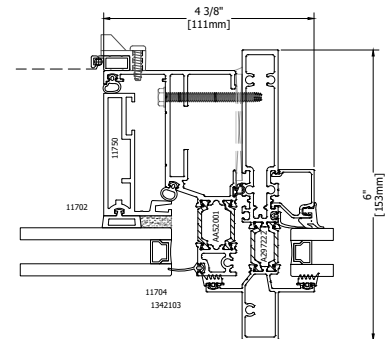

11C

December 2024

Typical details with 5000 Phantom Vent- double glazed
 Détails typiques avec 5000 Phantom Vent- double vitrage

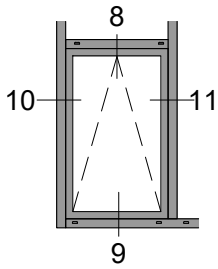

6.00" Deep
 w/ 5000 Phantom Vent
 Awning "EURO" MPL Handle

8B

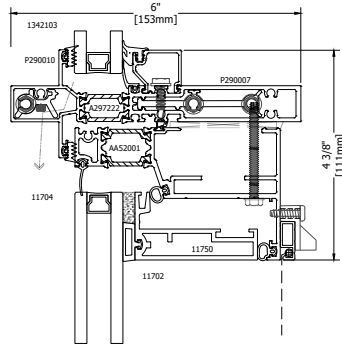

9B

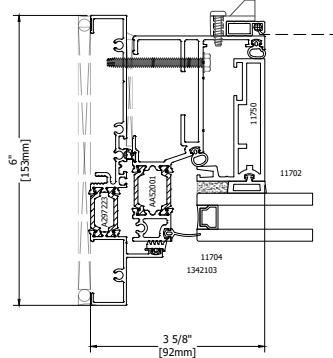
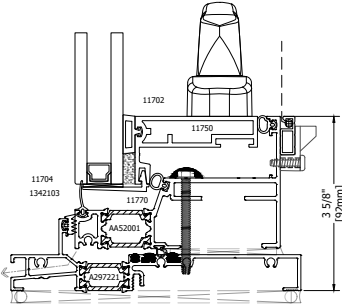

10B

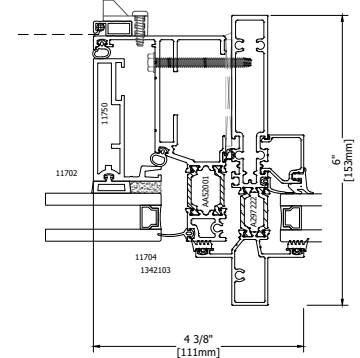

11B

6.00" Deep
 w/ 5000 Phantom Vent
 Awning ROTO & MPL Handle

8C

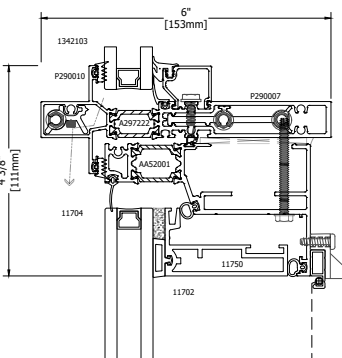

9C

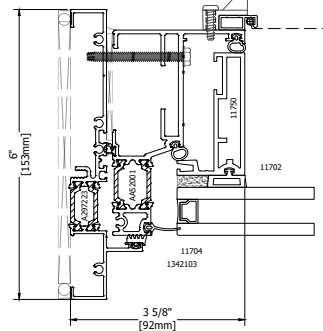
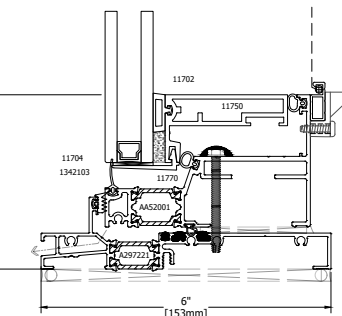

10C

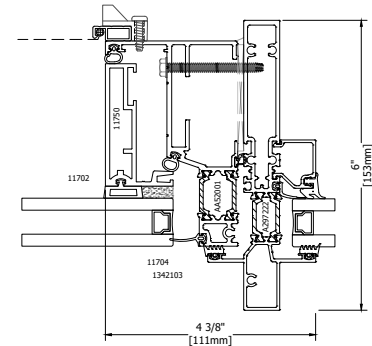

11C

December 2024

2970AW ShadowLine

Typical details - triple glazed
 Détails typiques - triple vitrage
 6.75" Deep

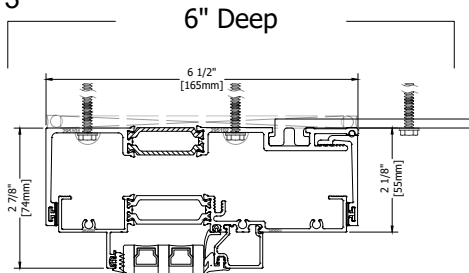
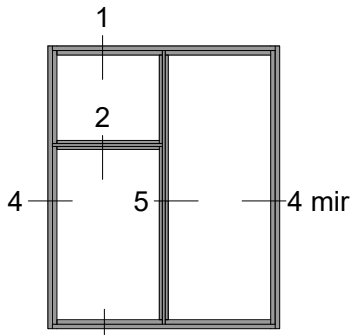

1A

OPTIONAL SILL
w/ HEAD RECEPTOR

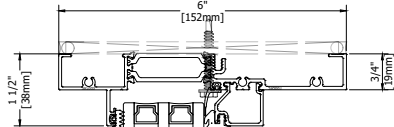

1

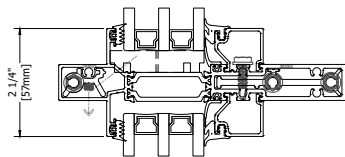

2

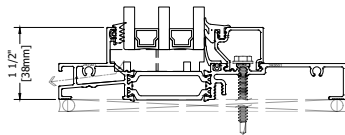

3

3A

OPTIONAL SILL
w/ SILL RECEPTOR

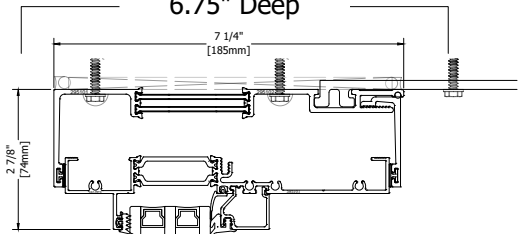
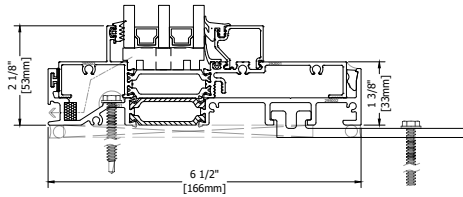

1A

OPTIONAL SILL
w/ SILL RECEPTOR

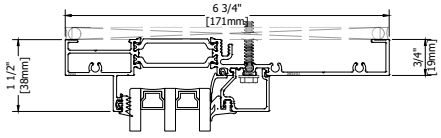

1

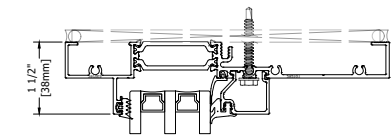

2

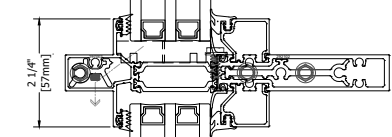

3

3A

OPTIONAL SILL
w/ SILL RECEPTOR

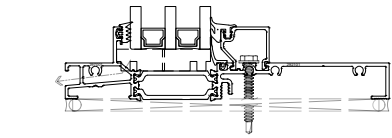

3B

OPTIONAL SILL
w/ EXTENDED SILL &
TREMCO PROGLAZE ETA

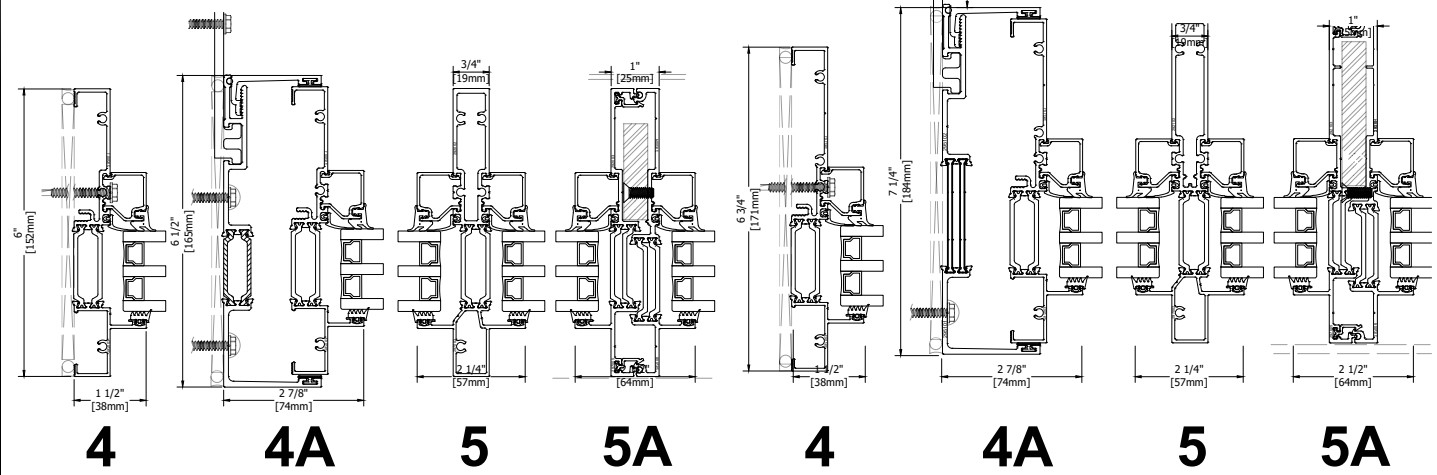
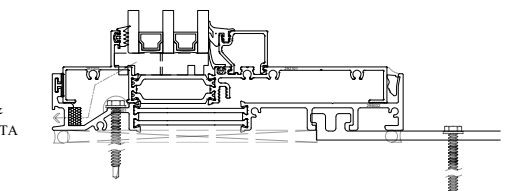

4

4A

5

5A

4

4A

5

5A

December 2024

For specific product applications, contact your representative.

www.alumicor.com

PAGE 19

www.tubeliteUSA.com



2970AW ShadowLine

Typical details - triple glazed
 Détails typiques - triple vitrage

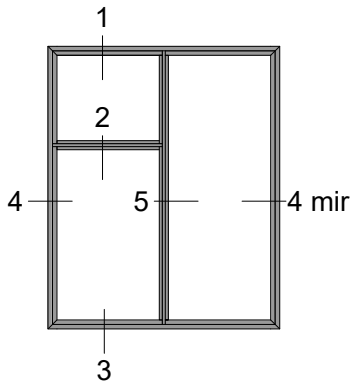

6" Deep

6.75" Deep

1
MITERED FRAME ASSEMBLY
∠ 45°

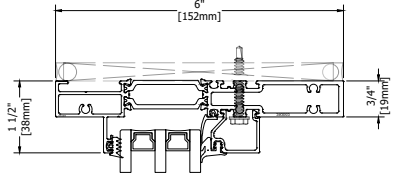

1
MITERED FRAME ASSEMBLY
∠ 45°

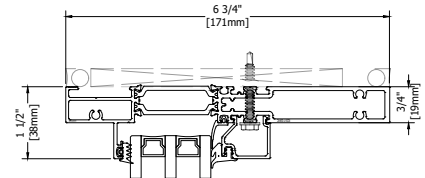

2

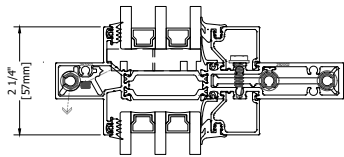

2

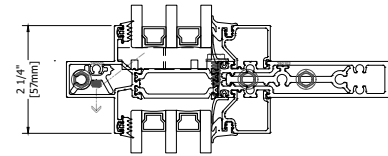

3

MITERED FRAME ASSEMBLY
∠ 45°

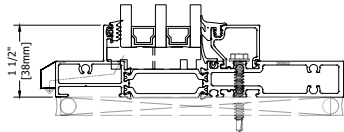

3

MITERED FRAME ASSEMBLY
∠ 45°

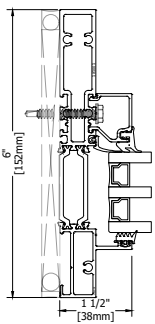
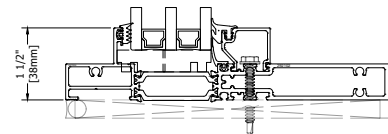

4

MITERED FRAME ASSEMBLY
∠ 45°

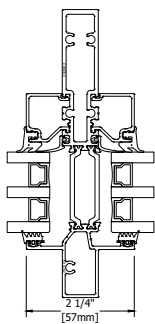

5

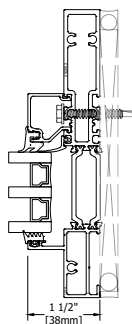

6

MITERED FRAME ASSEMBLY
∠ 45°

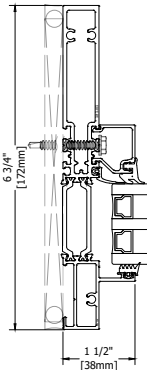

4

MITERED FRAME ASSEMBLY
∠ 45°

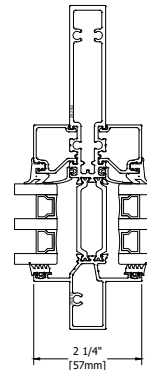

5

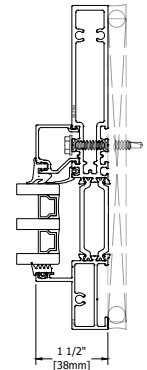

6

MITERED FRAME ASSEMBLY
∠ 45°

December 2024

2970AW ShadowLine

Typical details with 1375- triple glazed
 Détails typiques avec 1375 - triple vitrage

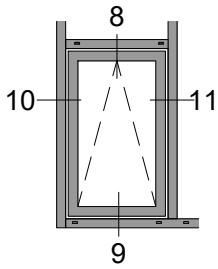

6" Deep
w/ 1375 PO Awning

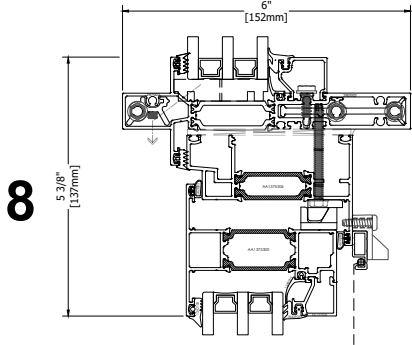

6.75" Deep
w/ 1375 PI HOPPER

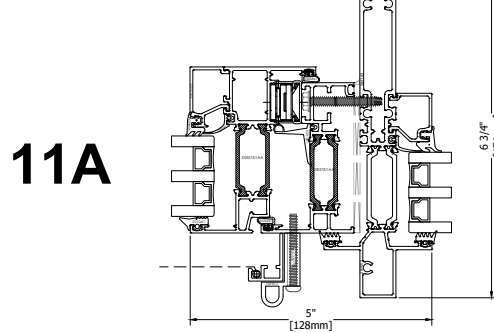
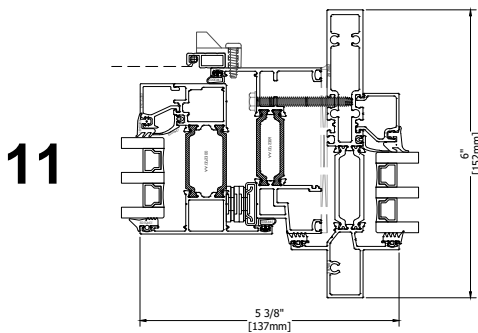
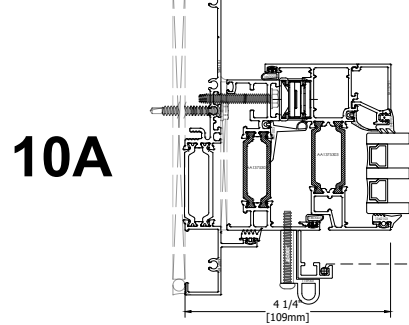
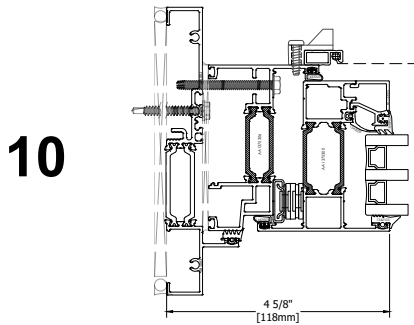
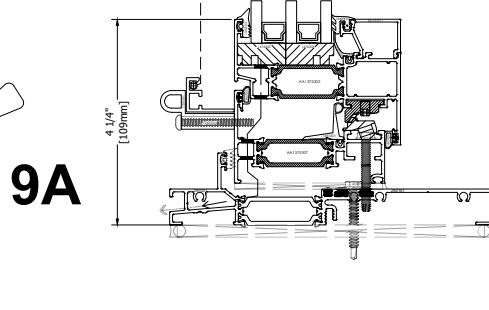
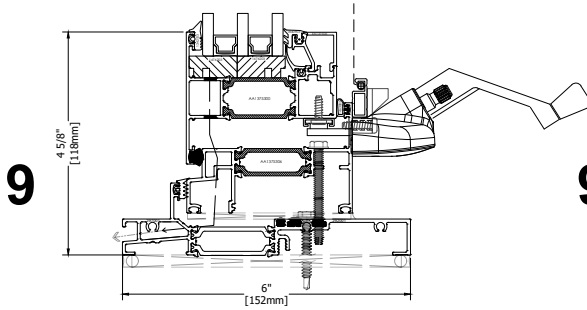
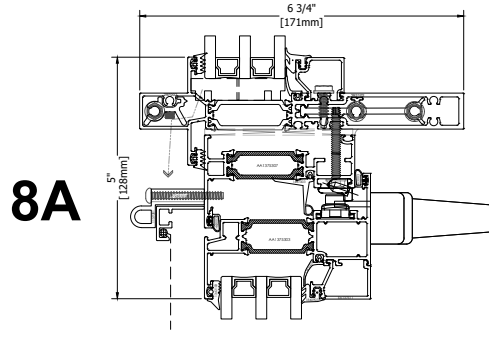

December 2024

2970AW ShadowLine

Typical details with 1375- triple glazed
 Détails typiques avec 1375 - triple vitrage

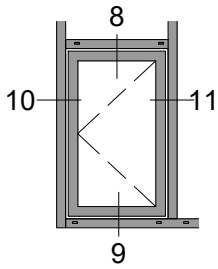

6" Deep
 w/ 1375 1375 PO Casement

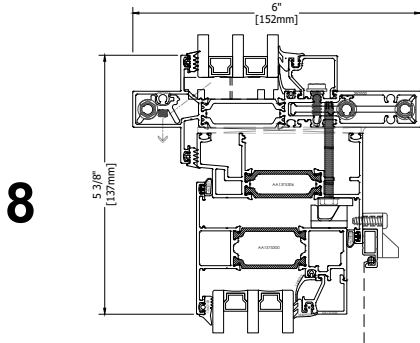

8

6.75" Deep
 w/ 1375 PI Casement

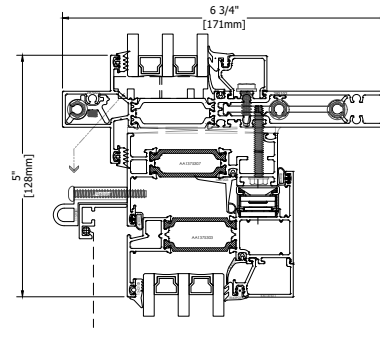

8A

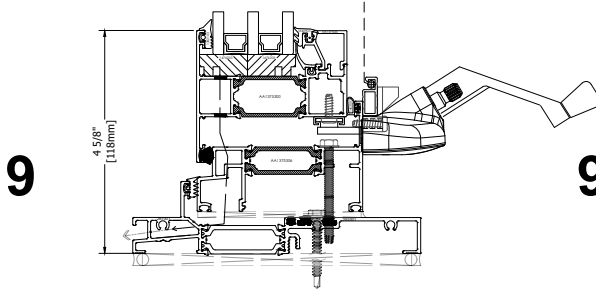

9

9A

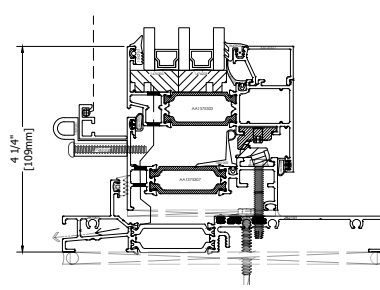

10

10A

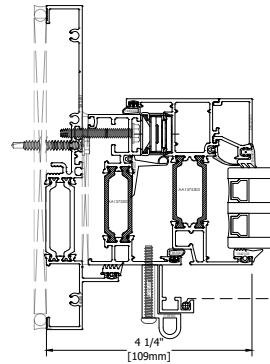
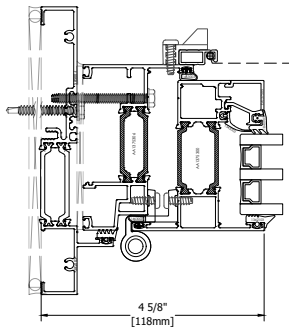

11

11A

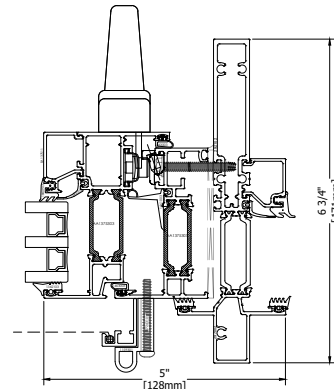
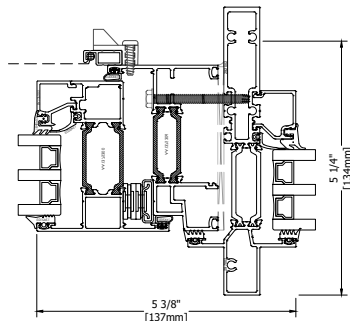

December 2024

2970AW ShadowLine

Typical details with 5000 Phantom Vent - triple glazed
Détails typiques avec 5000 Phantom Vent - triple vitrage

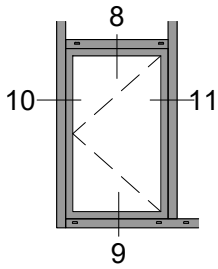

6.75" Deep
w/ 5000 Phantom Vent
Casement with "EURO" MPL Handle

8B

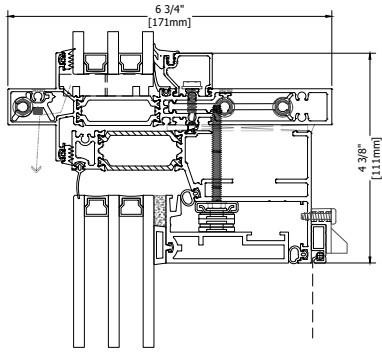

9B

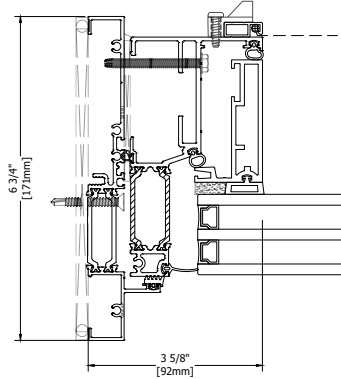
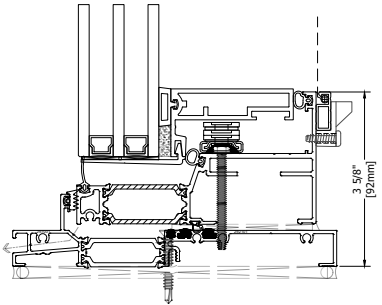

10B

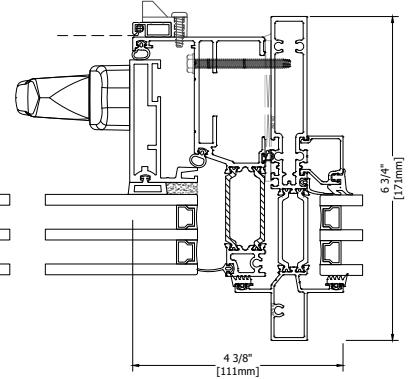

11B

December 2024

Typical details with 5000 Phantom Vent - triple glazed
 Détails typiques avec 5000 Phantom Vent - triple vitrage

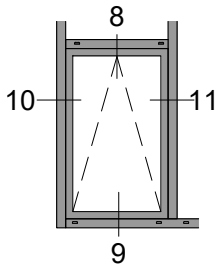

6.75" Deep
 w/ 5000 Phantom Vent
 Awning "EURO" MPL Handle

8B

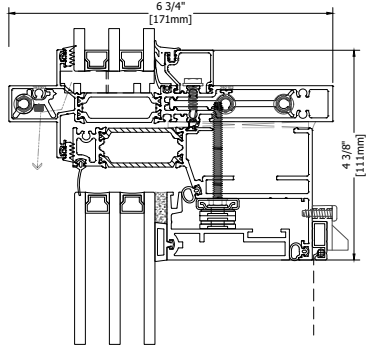

9B

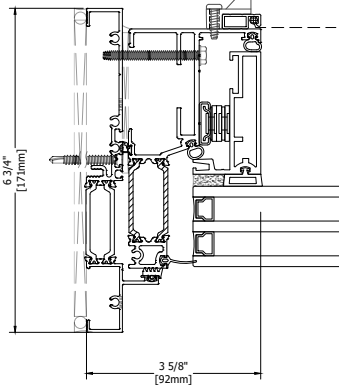
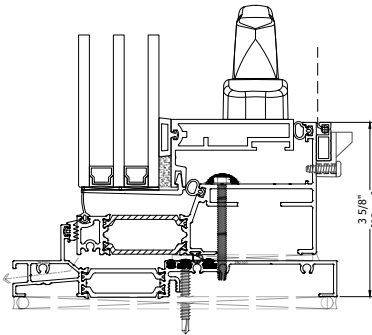

10B

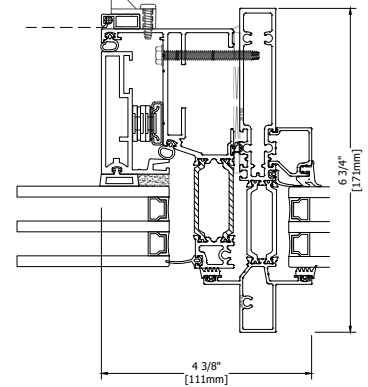

11B

6.75" Deep
 w/ 5000 Phantom Vent
 Awning ROTO & MPL Handle

8C

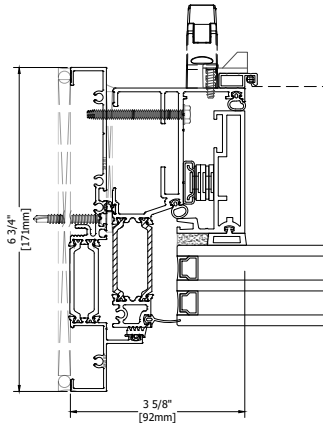
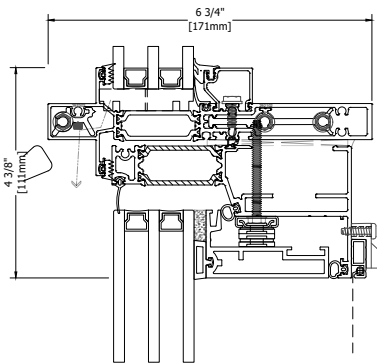

10C

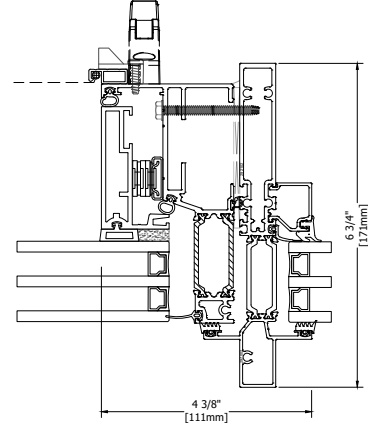

11C

9C

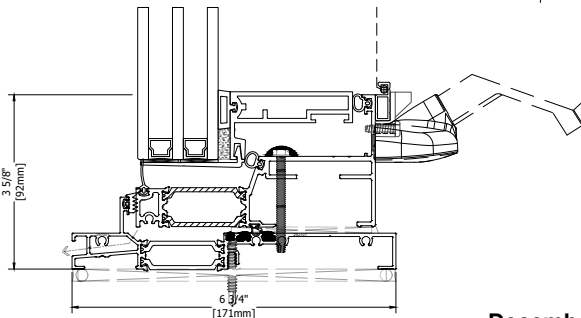

December 2024

2970AW ShadowLine

Typical details - double glazed
 Détails typiques - double vitrage
 7.00" Deep

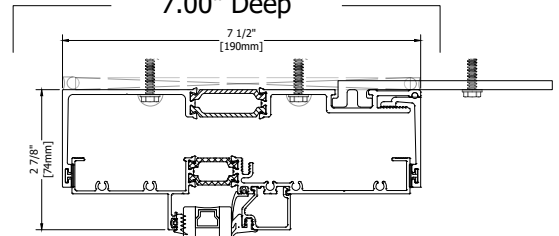
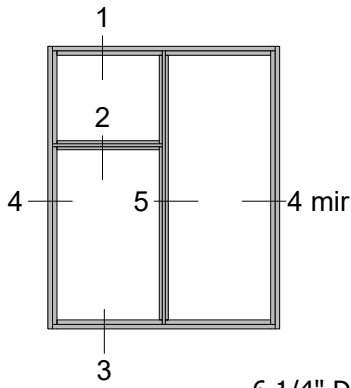

1A
 OPTIONAL
 w/ HEAD RECEPTOR

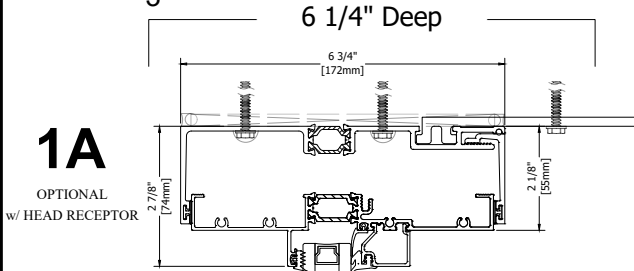

1A
 OPTIONAL
 w/ HEAD RECEPTOR

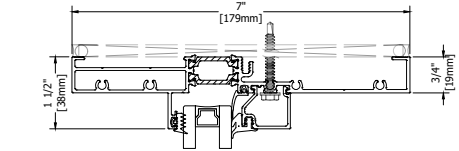

1

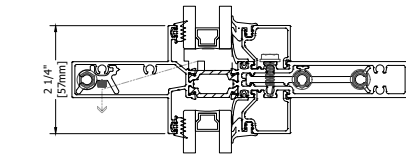

2

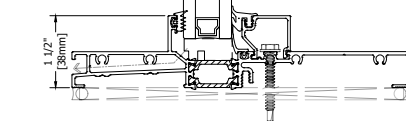

3

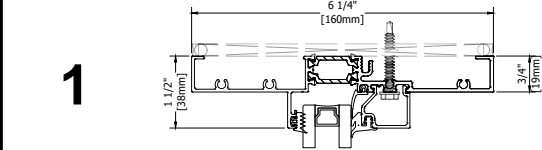

1

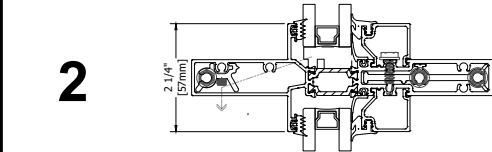

2

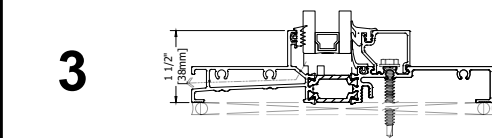

3

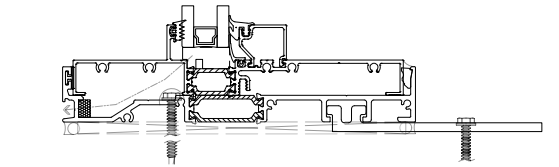

3A
 OPTIONAL SILL
 w/ SILL RECEPTOR

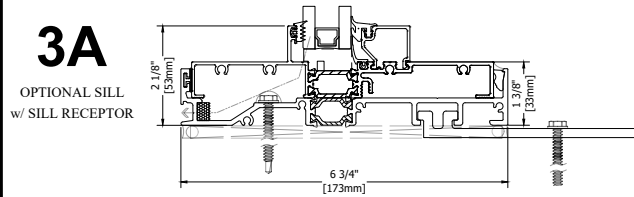

3A
 OPTIONAL SILL
 w/ SILL RECEPTOR

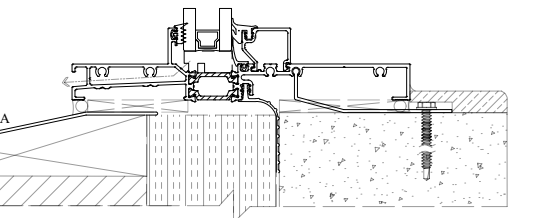

3B
 OPTIONAL SILL
 w/ EXTENDED SILL &
 TREMCO PROGLAZE ETA

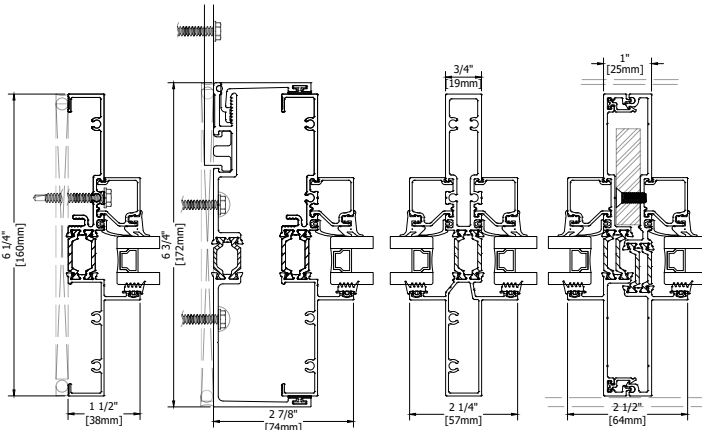

4

4A

5

5A

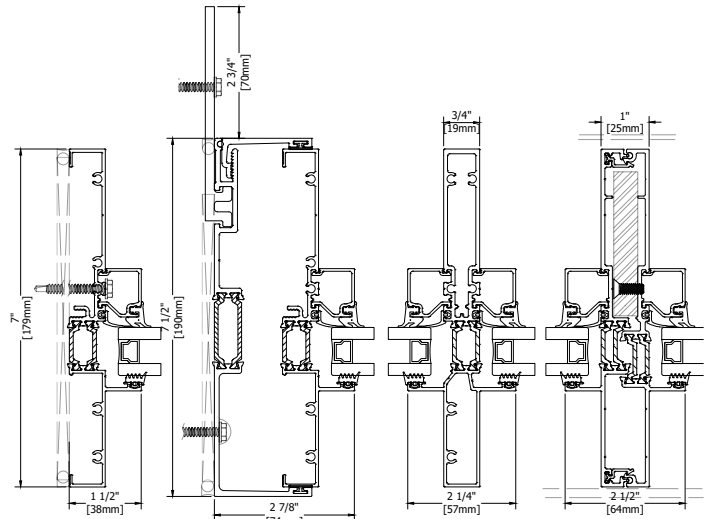

4

4A

5

5A

December 2024

2970AW ShadowLine

Typical details - double glazed
 Détails typiques - double vitrage

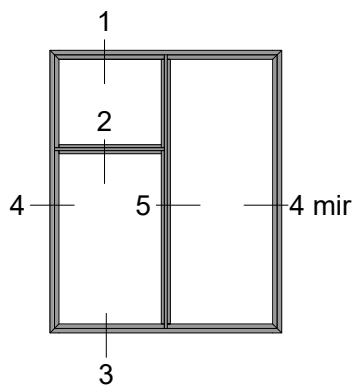

6 1/4" Deep

7.00" Deep

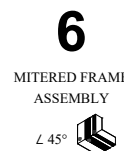
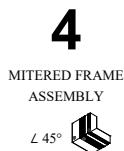
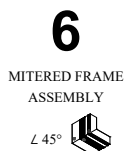
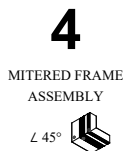
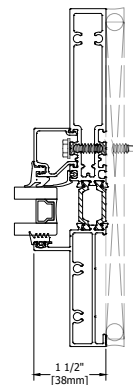
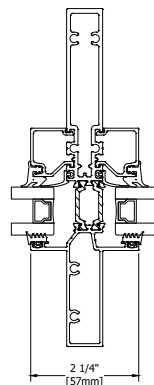
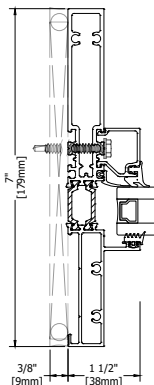
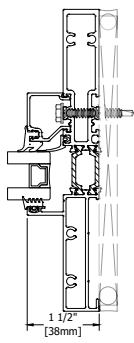
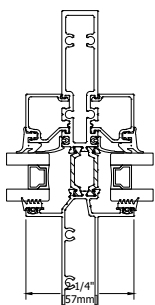
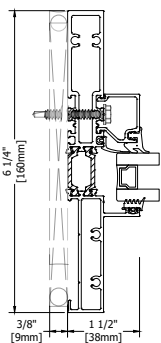
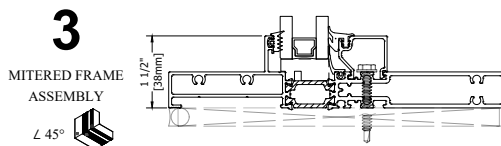
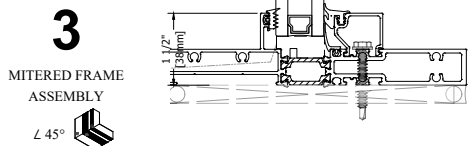
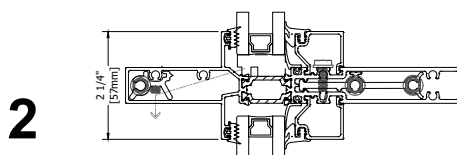
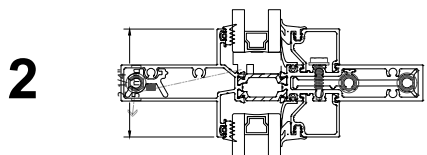
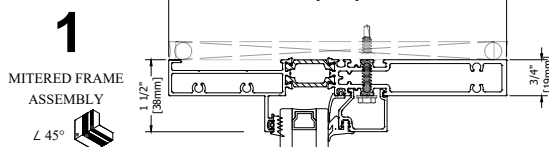
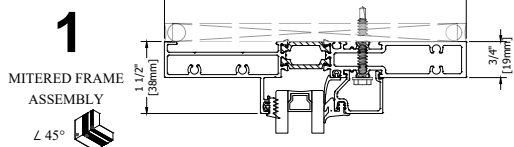

December 2024

2970AW ShadowLine

Typical details with 1375- double glazed
 Détails typiques avec 1375 - double vitrage

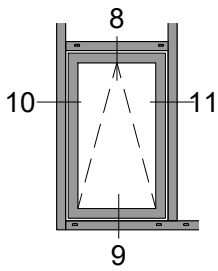

6 1/4" Deep
w/ 1375 PO Awning

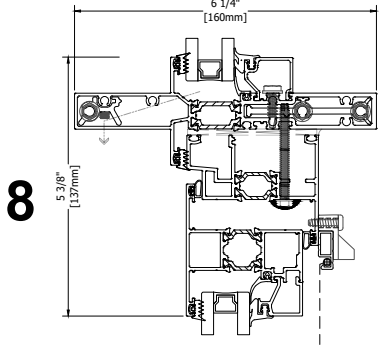

8

7.00" Deep
w/ 1375 PI HOPPER

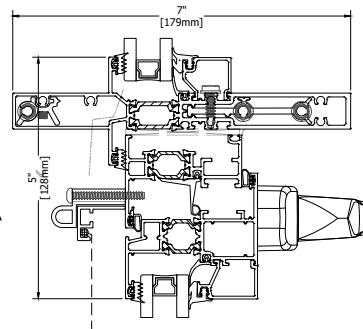

8A

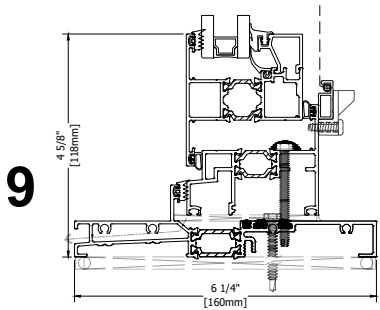

9

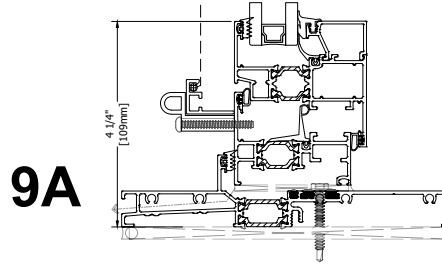

9A

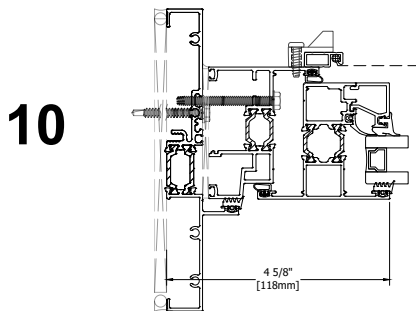

10

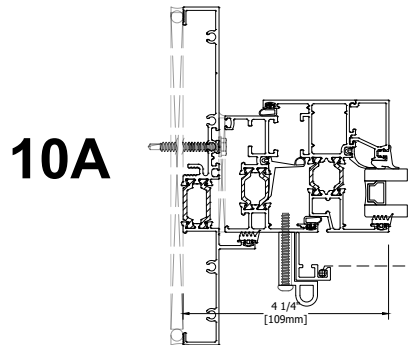

10A

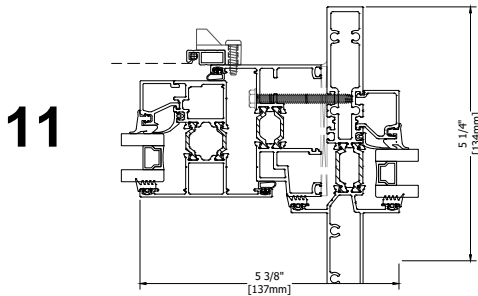

11

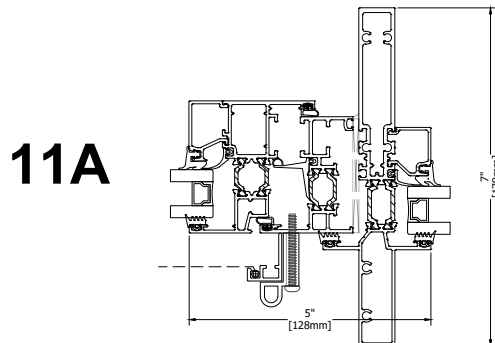

11A

December 2024

2970AW ShadowLine

Typical details with 1375- double glazed
 Détails typiques avec 1375 - double vitrage

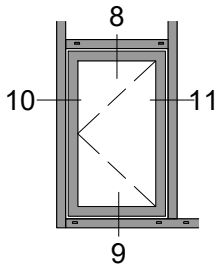

6" Deep
 w/ 1375 PO Casement

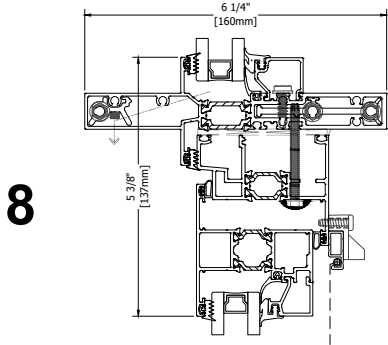

7.00" Deep
 w/ 1375 PI Casement

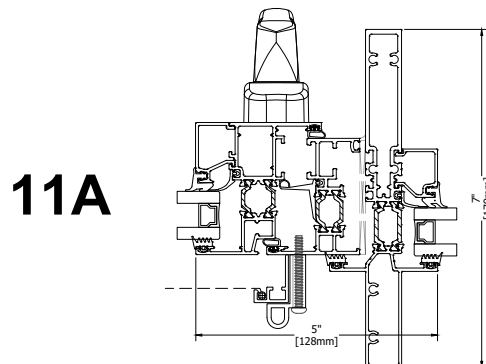
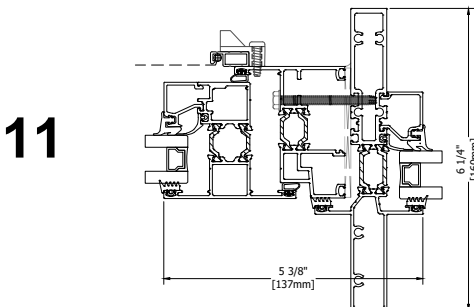
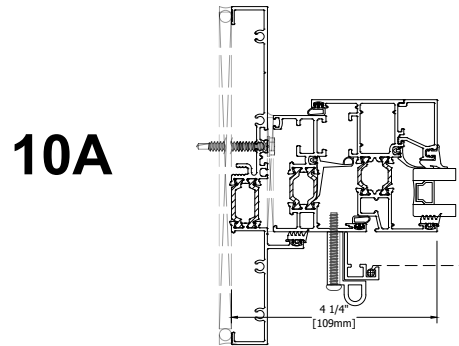
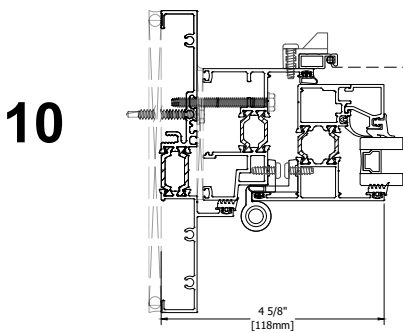
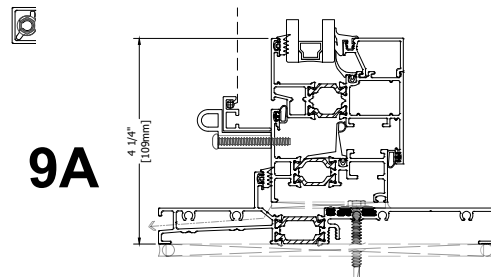
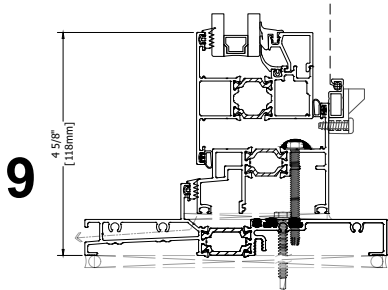
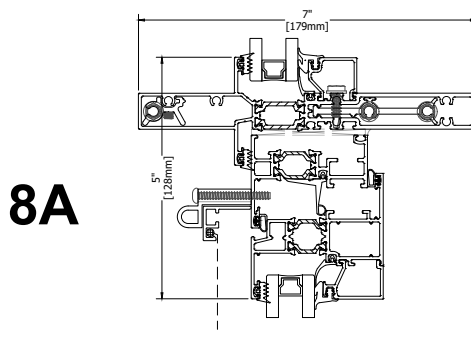

December 2024

2970AW ShadowLine

Typical details with 5000 Phantom Vent- double glazed
 Détails typiques avec 5000 Phantom Vent- double vitrage

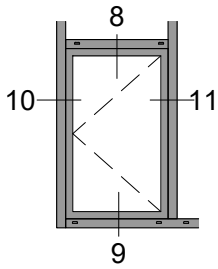

7.00" Deep
 w/ 5000 Phantom Vent
 Casement with "EURO" MPL Handle

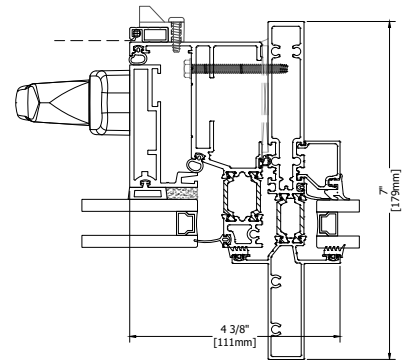
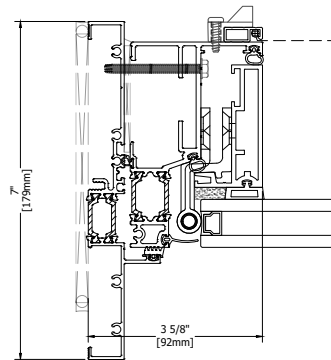
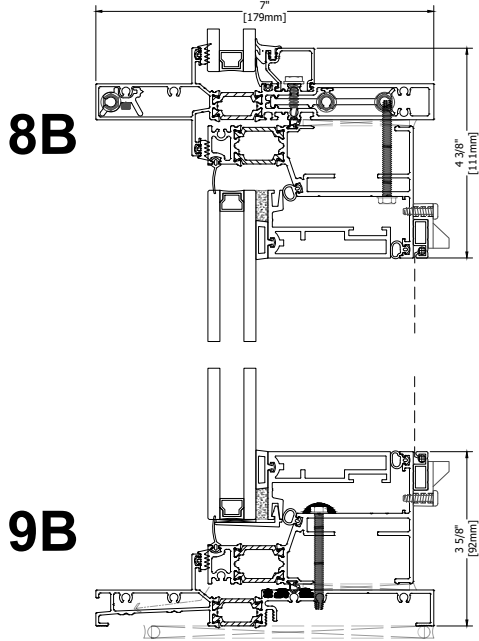

10B

11B

6.00" Deep
 w/ 5000 Phantom Vent
 Casement ROTO & MPL Handle

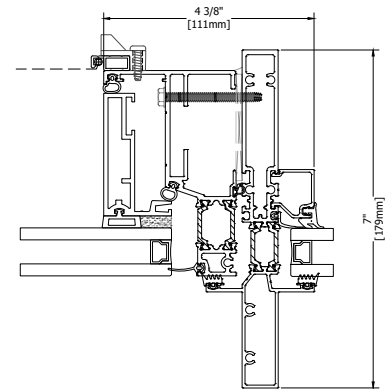
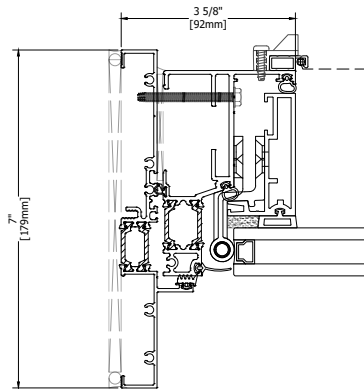
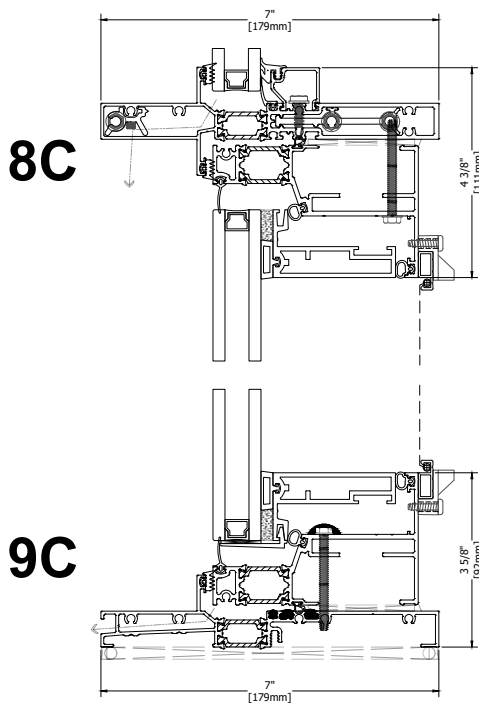

10C

11C

December 2024

2970AW ShadowLine

Typical details with 5000 Phantom Vent- double glazed
 Détails typiques avec 5000 Phantom Vent- double vitrage

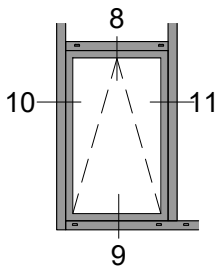

7.00" Deep
 w/ 5000 Phantom Vent
 Awning "EURO" MPL Handle

8B

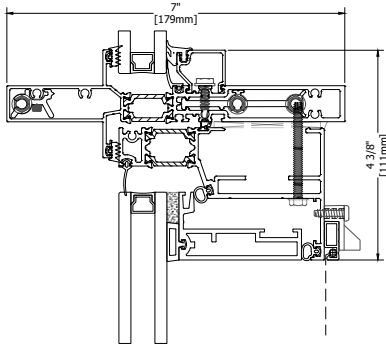

9B

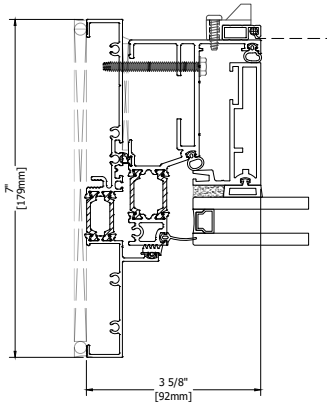
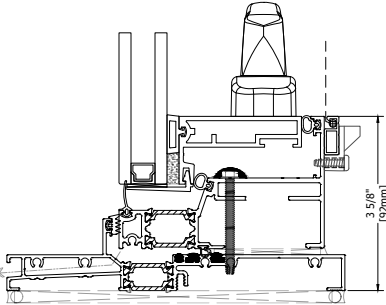

10B

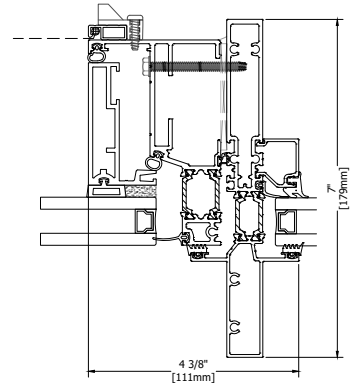

11B

7.00" Deep
 w/ 5000 Phantom Vent
 Awning ROTO & MPL Handle

8C

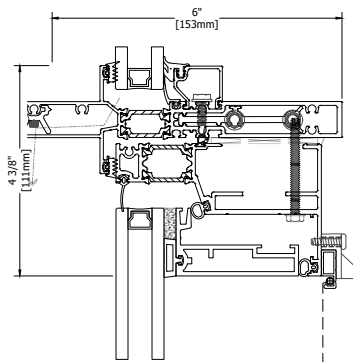

9C

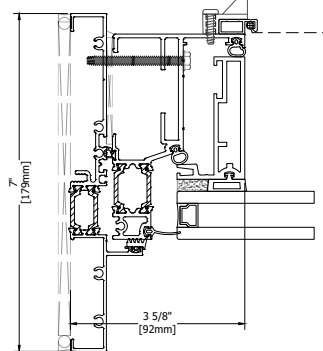
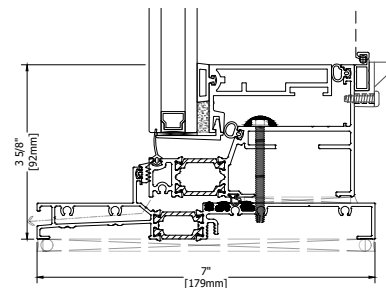

10C

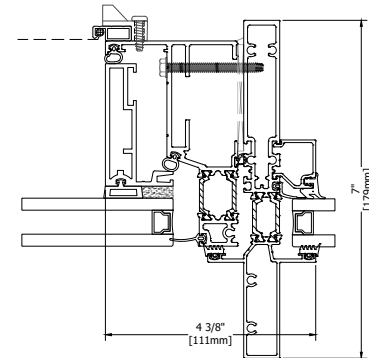

11C

December 2024